

TexPREP
San Antonio PREP

PREP II

Introduction to Physics



COMPILED BY:

Frank Matthew Juarez

Produced and Distributed by

TEXAS PREFRESHMEN ENGINEERING PROGRAM (TexPREP)

Raul "Rudy" Reyna, Director
Manuel P. Berriozabal, Founder
The University of Texas at San Antonio
San Antonio, Texas

**Texas & San Antonio Prefreshman Engineering Program
Introduction to Physics
PREP II**

SYLLABUS

INSTRUCTOR: _____

LECTURE TIME & ROOM NUMBER: _____

COURSE:
Problem Solving – Geometry

PREREQUISITE (S):
Algebra (I) and future enrollment in Geometry next school session.

COURSE DESCRIPTION & CONTENT:
The study of mathematics that deals with the measurement properties, and relationships to points, lines, angles, surfaces, and solids.

<u>GRADING SCHEME:</u>	Homework	30%
	Quizzes	10%
	Participation	10%
	Exams	25%
	Final Exam	25%

PREP Overall Grade Weight - 20%

*The instructor may alter class-grading scheme.

<u>GRADING SCALE:</u>	99.00 – 100.00	A+ (outstanding)
	98.00 – 98.99	A+ (honors)
	93.00 – 97.99	A
	85.00 – 92.99	B
	75.00 – 84.99	C
	69.50 – 74.99	D
	Below – 69.50	F

SCHOLASTIC DISHONESTY:
Cheating will not be tolerated and is grounds for dismissal from the program

Table of Contents & Weekly Objectives

Chapter One.....pg. 1-17

- I. Introduction to Physics – Past to Present
- II. Algebra & Geometry Review
- II. Measurements & Data Analysis
 - a. Units
 - b. Quantities
 - c. Mechanics
 - d. Dimensions

Chapter Two.....pg. 19-34

- I. Momentum & Inertia
- II. Scalars & Vectors
- III. Forces
 - a. Resultant Forces
 - b. Component Forces
 - c. Centripetal vs. Centrifugal
- IV. Rotational Motion
 - a. Torque (Moment)

Chapter Three.....pg. 36-43

- I. Statics
- II. Motion
 - a. Motion in One-Dimension (1-D) & Two-Dimension (2-D)
 - b. Motion in Three-Dimension (3-D)
- III. Newton's Laws of Motion
 - a. 1st Law & 2nd Law of Motion
 - b. 3rd Law
 - c. Newton's Kinematic Equations of Motion

Chapter Four.....pg.45-49

- I. Kinematics & Dynamics
 - a. Distance & Displacement
 - b. Speed & Velocity
 - c. Average Speed & Velocity
 - d. Acceleration.
 - 1. Constant Acceleration due to gravity
 - 2. Calculating Acceleration
 - 3. Direction of the Acceleration Vector

Chapter Five.....pg. 51-58

- I. Work & Energy
 - a. Conservation of Energy
 - b. Transfer of Energy
- II. Potential Energy
- III. Kinetic Energy
 - a. Mechanical Energy

Chapter Six.....pg. 60-68

- I. Fluid Mechanics
 - a. Fluid Flow and its properties
 - b. The Continuity Equation
 - c. Bernoulli's Equation
 - d. Boyle's Law

Chapter Seven.....pg. 70-103

- I. Electricity
 - a. Electrical Potential
 - b. Ohm's Law
 - c. Voltage, Current, & Resistance.
 - d. Power
 - e. Transformers (City Public Service of San Antonio)
- II. Optics
 - a. Refractions
 - b. Optical Density & Speed of Light
 - c. Refraction Angle
 - d. Snell's Law
 - e. Anatomy of a Lens

Referencespg. 104-105

Basic Physics Equations & Reference Table

CONSTANTS AND CONVERSION FACTORS		UNITS		PREFIXES																																		
		Name	Symbol	Factor	Prefix	Symbol																																
1 unified atomic mass unit,	$1 \text{ u} = 1.66 \times 10^{-27} \text{ kg}$	meter	m	10^9	giga	G																																
	$= 931 \text{ MeV}/c^2$	kilogram	kg	10^6	mega	M																																
Proton mass,	$m_p = 1.67 \times 10^{-27} \text{ kg}$	second	s	10^3	kilo	k																																
Neutron mass,	$m_n = 1.67 \times 10^{-27} \text{ kg}$	ampere	A	10^{-2}	centi	c																																
Electron mass,	$m_e = 9.11 \times 10^{-31} \text{ kg}$	kelvin	K	10^{-3}	milli	m																																
Magnitude of the electron charge,	$e = 1.60 \times 10^{-19} \text{ C}$	mole	mol	10^{-6}	micro	μ																																
Avogadro's number,	$N_0 = 6.02 \times 10^{23} \text{ mol}^{-1}$	hertz	Hz	10^{-9}	nano	n																																
Universal gas constant,	$R = 8.31 \text{ J}/(\text{mol} \cdot \text{K})$	newton	N	10^{-12}	pico	p																																
Boltzmann's constant,	$k_B = 1.38 \times 10^{-23} \text{ J/K}$	pascal	Pa	VALUES OF TRIGONOMETRIC FUNCTIONS FOR COMMON ANGLES <table border="1" style="width: 100%; border-collapse: collapse; margin-top: 10px;"> <thead> <tr> <th style="text-align: center;">θ</th> <th style="text-align: center;">$\sin \theta$</th> <th style="text-align: center;">$\cos \theta$</th> <th style="text-align: center;">$\tan \theta$</th> </tr> </thead> <tbody> <tr> <td style="text-align: center;">0°</td> <td style="text-align: center;">0</td> <td style="text-align: center;">1</td> <td style="text-align: center;">0</td> </tr> <tr> <td style="text-align: center;">30°</td> <td style="text-align: center;">1/2</td> <td style="text-align: center;">$\sqrt{3}/2$</td> <td style="text-align: center;">$\sqrt{3}/3$</td> </tr> <tr> <td style="text-align: center;">37°</td> <td style="text-align: center;">3/5</td> <td style="text-align: center;">4/5</td> <td style="text-align: center;">3/4</td> </tr> <tr> <td style="text-align: center;">45°</td> <td style="text-align: center;">$\sqrt{2}/2$</td> <td style="text-align: center;">$\sqrt{2}/2$</td> <td style="text-align: center;">1</td> </tr> <tr> <td style="text-align: center;">53°</td> <td style="text-align: center;">4/5</td> <td style="text-align: center;">3/5</td> <td style="text-align: center;">4/3</td> </tr> <tr> <td style="text-align: center;">60°</td> <td style="text-align: center;">$\sqrt{3}/2$</td> <td style="text-align: center;">1/2</td> <td style="text-align: center;">$\sqrt{3}$</td> </tr> <tr> <td style="text-align: center;">90°</td> <td style="text-align: center;">1</td> <td style="text-align: center;">0</td> <td style="text-align: center;">∞</td> </tr> </tbody> </table>			θ	$\sin \theta$	$\cos \theta$	$\tan \theta$	0°	0	1	0	30°	1/2	$\sqrt{3}/2$	$\sqrt{3}/3$	37°	3/5	4/5	3/4	45°	$\sqrt{2}/2$	$\sqrt{2}/2$	1	53°	4/5	3/5	4/3	60°	$\sqrt{3}/2$	1/2	$\sqrt{3}$	90°	1	0	∞
θ	$\sin \theta$	$\cos \theta$	$\tan \theta$																																			
0°	0	1	0																																			
30°	1/2	$\sqrt{3}/2$	$\sqrt{3}/3$																																			
37°	3/5	4/5	3/4																																			
45°	$\sqrt{2}/2$	$\sqrt{2}/2$	1																																			
53°	4/5	3/5	4/3																																			
60°	$\sqrt{3}/2$	1/2	$\sqrt{3}$																																			
90°	1	0	∞																																			
Speed of light,	$c = 3.00 \times 10^8 \text{ m/s}$	joule	J																																			
Planck's constant,	$h = 6.63 \times 10^{-34} \text{ J} \cdot \text{s}$	watt	W																																			
	$= 4.14 \times 10^{-15} \text{ eV} \cdot \text{s}$	coulomb	C																																			
	$hc = 1.99 \times 10^{-25} \text{ J} \cdot \text{m}$	volt	V																																			
	$= 1.24 \times 10^3 \text{ eV} \cdot \text{nm}$	ohm	Ω																																			
Vacuum permittivity,	$\epsilon_0 = 8.85 \times 10^{-12} \text{ C}^2/\text{N} \cdot \text{m}^2$	henry	H																																			
Coulomb's law constant,	$k = 1/4\pi\epsilon_0 = 9.0 \times 10^9 \text{ N} \cdot \text{m}^2/\text{C}^2$	farad	F																																			
Vacuum permeability,	$\mu_0 = 4\pi \times 10^{-7} (\text{T} \cdot \text{m})/\text{A}$	tesla	T																																			
Magnetic constant,	$k' = \mu_0/4\pi = 10^{-7} (\text{T} \cdot \text{m})/\text{A}$	degree																																				
Universal gravitational constant,	$G = 6.67 \times 10^{-11} \text{ m}^3/\text{kg} \cdot \text{s}^2$	Celsius	$^\circ\text{C}$																																			
Acceleration due to gravity at the Earth's surface,	$g = 9.8 \text{ m/s}^2$	electron-volt	eV																																			
1 atmosphere pressure,	$1 \text{ atm} = 1.0 \times 10^5 \text{ N/m}^2$																																					
	$= 1.0 \times 10^5 \text{ Pa}$																																					
1 electron volt,	$1 \text{ eV} = 1.60 \times 10^{-19} \text{ J}$																																					

The following conventions are used in this examination.

- I. Unless otherwise stated, the frame of reference of any problem is assumed to be inertial.
- II. The direction of any electric current is the direction of flow of positive charge (conventional current).
- III. For any isolated electric charge, the electric potential is defined as zero at an infinite distance from the charge.
- *IV. For mechanics and thermodynamics equations, W represents the work done on a system.

NEWTONIAN MECHANICS

$$v = v_0 + at$$

$$x = x_0 + v_0 t + \frac{1}{2} at^2$$

$$v^2 = v_0^2 + 2a(x - x_0)$$

$$\Sigma \mathbf{F} = \mathbf{F}_{net} = m\mathbf{a}$$

$$F_{fric} \leq \mu N$$

$$a_c = \frac{v^2}{r}$$

$$\tau = rF \sin \theta$$

$$\mathbf{p} = m\mathbf{v}$$

$$\mathbf{J} = \mathbf{F}\Delta t = \Delta \mathbf{p}$$

$$K = \frac{1}{2} mv^2$$

$$\Delta U_g = mgh$$

$$W = \mathbf{F} \cdot \Delta \mathbf{r} = F\Delta r \cos \theta$$

$$P_{avg} = \frac{W}{\Delta t}$$

$$P = \mathbf{F} \cdot \mathbf{v} = Fv \cos \theta$$

$$\mathbf{F}_s = -k\mathbf{x}$$

$$U_s = \frac{1}{2} kx^2$$

$$T_s = 2\pi \sqrt{\frac{m}{k}}$$

$$T_p = 2\pi \sqrt{\frac{\ell}{g}}$$

$$T = \frac{1}{f}$$

$$F_G = -\frac{Gm_1 m_2}{r^2}$$

$$U_G = -\frac{Gm_1 m_2}{r}$$

a = acceleration
 F = force
 f = frequency
 h = height
 J = impulse
 K = kinetic energy
 k = spring constant
 ℓ = length
 m = mass
 N = normal force
 P = power
 p = momentum
 r = radius or distance
 \mathbf{r} = position vector
 T = period
 t = time
 U = potential energy
 v = velocity or speed
 W = work done on a system
 x = position
 μ = coefficient of friction
 θ = angle
 τ = torque

ELECTRICITY AND MAGNETISM

$$F = \frac{1}{4\pi\epsilon_0} \frac{q_1 q_2}{r^2}$$

$$\mathbf{E} = \frac{\mathbf{F}}{q}$$

$$U_E = qV = \frac{1}{4\pi\epsilon_0} \frac{q_1 q_2}{r}$$

$$E_{avg} = -\frac{V}{d}$$

$$V = \frac{1}{4\pi\epsilon_0} \sum_i \frac{q_i}{r_i}$$

$$C = \frac{Q}{V}$$

$$C = \frac{\epsilon_0 A}{d}$$

$$U_c = \frac{1}{2} QV = \frac{1}{2} CV^2$$

$$I_{avg} = \frac{\Delta Q}{\Delta t}$$

$$R = \frac{\rho \ell}{A}$$

$$V = IR$$

$$P = IV$$

$$C_p = \sum_i C_i$$

$$\frac{1}{C_s} = \sum_i \frac{1}{C_i}$$

$$R_s = \sum_i R_i$$

$$\frac{1}{R_p} = \sum_i \frac{1}{R_i}$$

$$F_B = qvB \sin \theta$$

$$F_B = BI\ell \sin \theta$$

$$B = \frac{\mu_0 I}{2\pi r}$$

$$\phi_m = \mathbf{B} \cdot \mathbf{A} = BA \cos \theta$$

$$\mathcal{E}_{avg} = -\frac{\Delta \phi_m}{\Delta t}$$

$$\mathcal{E} = B\ell v$$

A = area
 B = magnetic field
 C = capacitance
 d = distance
 E = electric field
 \mathcal{E} = emf
 F = force
 I = current
 ℓ = length
 P = power
 Q = charge
 q = point charge
 R = resistance
 r = distance
 t = time
 U = potential (stored) energy
 V = electric potential or potential difference
 v = velocity or speed
 ρ = resistivity
 ϕ_m = magnetic flux

FLUID MECHANICS AND THERMAL PHYSICS

$$p = p_0 + \rho gh$$

$$F_{buoy} = \rho Vg$$

$$A_1 v_1 = A_2 v_2$$

$$p + \rho gy + \frac{1}{2} \rho v^2 = \text{const.}$$

$$\Delta \ell = \alpha \ell_0 \Delta T$$

$$Q = mL$$

$$Q = mc\Delta T$$

$$p = \frac{F}{A}$$

$$pV = nRT$$

$$K_{avg} = \frac{3}{2} k_B T$$

$$v_{rms} = \sqrt{\frac{3RT}{M}} = \sqrt{\frac{3k_B T}{\mu}}$$

$$W = -p\Delta V$$

$$Q = nc\Delta T$$

$$\Delta U = Q + W$$

$$\Delta U = nc_V \Delta T$$

$$e = \left| \frac{W}{Q_H} \right|$$

$$e_c = \frac{T_H - T_C}{T_H}$$

A = area

c = specific heat or molar specific heat

e = efficiency

F = force

h = depth

K_{avg} = average molecular kinetic energy

L = heat of transformation

ℓ = length

M = molecular mass

m = mass of sample

n = number of moles

p = pressure

Q = heat transferred to a system

T = temperature

U = internal energy

V = volume

v = velocity or speed

v_{rms} = root-mean-square velocity

W = work done on a system

y = height

α = coefficient of linear expansion

μ = mass of molecule

ρ = density

ATOMIC AND NUCLEAR PHYSICS

$$E = hf = pc$$

$$K_{max} = hf - \phi$$

$$\lambda = \frac{h}{p}$$

$$\Delta E = (\Delta m)c^2$$

E = energy

f = frequency

K = kinetic energy

m = mass

p = momentum

λ = wavelength

ϕ = work function

WAVES AND OPTICS

$$v = f\lambda$$

$$n = \frac{c}{v}$$

$$n_1 \sin \theta_1 = n_2 \sin \theta_2$$

$$\sin \theta_c = \frac{n_2}{n_1}$$

$$\frac{1}{s_i} + \frac{1}{s_o} = \frac{1}{f}$$

$$M = \frac{h_i}{h_o} = -\frac{s_i}{s_o}$$

$$f = \frac{R}{2}$$

$$d \sin \theta = m\lambda$$

$$x_m \approx \frac{m\lambda L}{d}$$

d = separation

f = frequency or focal length

h = height

L = distance

M = magnification

m = an integer

n = index of refraction

R = radius of curvature

s = distance

v = speed

x = position

λ = wavelength

θ = angle

GEOMETRY AND TRIGONOMETRY

Rectangle

$$A = bh$$

Triangle

$$A = \frac{1}{2} bh$$

Circle

$$A = \pi r^2$$

$$C = 2\pi r$$

Parallelepiped

$$V = \ell wh$$

Cylinder

$$V = \pi r^2 \ell$$

$$S = 2\pi r \ell + 2\pi r^2$$

Sphere

$$V = \frac{4}{3} \pi r^3$$

$$S = 4\pi r^2$$

Right Triangle

$$a^2 + b^2 = c^2$$

$$\sin \theta = \frac{a}{c}$$

$$\cos \theta = \frac{b}{c}$$

$$\tan \theta = \frac{a}{b}$$

A = area

C = circumference

V = volume

S = surface area

b = base

h = height

ℓ = length

w = width

r = radius

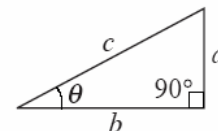

MECHANICS

$v = v_0 + at$ $x = x_0 + v_0t + \frac{1}{2}at^2$ $v^2 = v_0^2 + 2a(x - x_0)$ $\sum \mathbf{F} = \mathbf{F}_{net} = m\mathbf{a}$ $\mathbf{F} = \frac{d\mathbf{p}}{dt}$ $\mathbf{J} = \int \mathbf{F} dt = \Delta\mathbf{p}$ $\mathbf{p} = m\mathbf{v}$ $F_{fric} \leq \mu N$ $W = \int \mathbf{F} \cdot d\mathbf{r}$ $K = \frac{1}{2}mv^2$ $P = \frac{dW}{dt}$ $P = \mathbf{F} \cdot \mathbf{v}$ $\Delta U_g = mgh$ $a_c = \frac{v^2}{r} = \omega^2 r$ $\boldsymbol{\tau} = \mathbf{r} \times \mathbf{F}$ $\sum \boldsymbol{\tau} = \boldsymbol{\tau}_{net} = I\boldsymbol{\alpha}$ $I = \int r^2 dm = \sum mr^2$ $\mathbf{r}_{cm} = \sum m\mathbf{x} / \sum m$ $v = r\omega$ $\mathbf{L} = \mathbf{r} \times \mathbf{p} = I\boldsymbol{\omega}$ $K = \frac{1}{2}I\omega^2$ $\omega = \omega_0 + \alpha t$ $\theta = \theta_0 + \omega_0 t + \frac{1}{2}\alpha t^2$ $\mathbf{F}_s = -k\mathbf{x}$ $U_s = \frac{1}{2}kx^2$ $T = \frac{2\pi}{\omega} = \frac{1}{f}$ $T_s = 2\pi\sqrt{\frac{m}{k}}$ $T_p = 2\pi\sqrt{\frac{\ell}{g}}$ $\mathbf{F}_G = -\frac{Gm_1m_2}{r^2} \hat{\mathbf{r}}$ $U_G = -\frac{Gm_1m_2}{r}$	$a = \text{acceleration}$ $F = \text{force}$ $f = \text{frequency}$ $h = \text{height}$ $I = \text{rotational inertia}$ $J = \text{impulse}$ $K = \text{kinetic energy}$ $k = \text{spring constant}$ $\ell = \text{length}$ $L = \text{angular momentum}$ $m = \text{mass}$ $N = \text{normal force}$ $P = \text{power}$ $p = \text{momentum}$ $r = \text{radius or distance}$ $\mathbf{r} = \text{position vector}$ $T = \text{period}$ $t = \text{time}$ $U = \text{potential energy}$ $v = \text{velocity or speed}$ $W = \text{work done on a system}$ $x = \text{position}$ $\mu = \text{coefficient of friction}$ $\theta = \text{angle}$ $\boldsymbol{\tau} = \text{torque}$ $\omega = \text{angular speed}$ $\alpha = \text{angular acceleration}$
---	---

ELECTRICITY AND MAGNETISM

$F = \frac{1}{4\pi\epsilon_0} \frac{q_1q_2}{r^2}$ $\mathbf{E} = \frac{\mathbf{F}}{q}$ $\oint \mathbf{E} \cdot d\mathbf{A} = \frac{Q}{\epsilon_0}$ $E = -\frac{dV}{dr}$ $V = \frac{1}{4\pi\epsilon_0} \sum_i \frac{q_i}{r_i}$ $U_E = qV = \frac{1}{4\pi\epsilon_0} \frac{q_1q_2}{r}$ $C = \frac{Q}{V}$ $C = \frac{\kappa\epsilon_0 A}{d}$ $C_p = \sum_i C_i$ $\frac{1}{C_s} = \sum_i \frac{1}{C_i}$ $I = \frac{dQ}{dt}$ $U_C = \frac{1}{2}QV = \frac{1}{2}CV^2$ $R = \frac{\rho\ell}{A}$ $V = IR$ $R_s = \sum_i R_i$ $\frac{1}{R_p} = \sum_i \frac{1}{R_i}$ $P = IV$ $\mathbf{F}_M = q\mathbf{v} \times \mathbf{B}$ $\oint \mathbf{B} \cdot d\boldsymbol{\ell} = \mu_0 I$ $\mathbf{F} = \int I d\boldsymbol{\ell} \times \mathbf{B}$ $B_s = \mu_0 nI$ $\phi_m = \int \mathbf{B} \cdot d\mathbf{A}$ $\mathcal{E} = -\frac{d\phi_m}{dt}$ $\mathcal{E} = -L \frac{dI}{dt}$ $U_L = \frac{1}{2}LI^2$	$A = \text{area}$ $B = \text{magnetic field}$ $C = \text{capacitance}$ $d = \text{distance}$ $E = \text{electric field}$ $\mathcal{E} = \text{emf}$ $F = \text{force}$ $I = \text{current}$ $L = \text{inductance}$ $\ell = \text{length}$ $n = \text{number of loops of wire per unit length}$ $P = \text{power}$ $Q = \text{charge}$ $q = \text{point charge}$ $R = \text{resistance}$ $r = \text{distance}$ $t = \text{time}$ $U = \text{potential or stored energy}$ $V = \text{electric potential}$ $v = \text{velocity or speed}$ $\rho = \text{resistivity}$ $\phi_m = \text{magnetic flux}$ $\kappa = \text{dielectric constant}$
--	---

GEOMETRY AND TRIGONOMETRY

Rectangle

$$A = bh$$

Triangle

$$A = \frac{1}{2}bh$$

Circle

$$A = \pi r^2$$

$$C = 2\pi r$$

Parallelepiped

$$V = \ell wh$$

Cylinder

$$V = \pi r^2 \ell$$

$$S = 2\pi r \ell + 2\pi r^2$$

Sphere

$$V = \frac{4}{3}\pi r^3$$

$$S = 4\pi r^2$$

Right Triangle

$$a^2 + b^2 = c^2$$

$$\sin \theta = \frac{a}{c}$$

$$\cos \theta = \frac{b}{c}$$

$$\tan \theta = \frac{a}{b}$$

A = area
 C = circumference
 V = volume
 S = surface area
 b = base
 h = height
 ℓ = length
 w = width
 r = radius

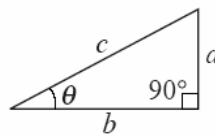

CALCULUS

$$\frac{df}{dx} = \frac{df}{du} \frac{du}{dx}$$

$$\frac{d}{dx}(x^n) = nx^{n-1}$$

$$\frac{d}{dx}(e^x) = e^x$$

$$\frac{d}{dx}(\ln x) = \frac{1}{x}$$

$$\frac{d}{dx}(\sin x) = \cos x$$

$$\frac{d}{dx}(\cos x) = -\sin x$$

$$\int x^n dx = \frac{1}{n+1} x^{n+1}, n \neq -1$$

$$\int e^x dx = e^x$$

$$\int \frac{dx}{x} = \ln|x|$$

$$\int \cos x dx = \sin x$$

$$\int \sin x dx = -\cos x$$

- Chapter One -

- I. Introduction to Physics – Past to Present
- II. Algebra & Geometry Review
- III. Measurements & Data Analysis
 - a. Units
 - e. Quantities
 - f. Mechanics
 - g. Dimensions

I. Introduction to Physics

Physics (from the Greek word *phusikos*, meaning "natural", and *phusis*, "nature") is the science of nature in the broadest sense. Physicists study the behavior and properties of matter in a wide variety of contexts, ranging from the sub-nuclear particles from which all ordinary matter is made (a.k.a particle physics) to the behavior of the material Universe as a whole (a.k.a. cosmology).

As a PREP II student, you must recall the lessons you learned in the Introduction to Engineering course in PREP I. Many of the properties studied in physics are common to all material systems, such as the conservation of energy. Such properties are often referred to as **laws of physics**. Physics is sometimes referred to as said the "fundamental science", because each of the other natural sciences (biology, chemistry, geology, etc.) deals with particular types of material systems which obey the laws of physics. For instance, chemistry is the science of molecules and the compounds they form together. The properties of a chemical are governed by the properties of the underlying molecules, which are accurately described by areas of physics such as quantum mechanics, thermodynamics, and electromagnetism.

Physics is also very closely related to *mathematics*. Physical theories are almost invariably expressed using mathematical relations, and the mathematics involved is commonly more complicated than in the other sciences. **The primary difference between physics and mathematics is that physics is ultimately concerned with descriptions of the material world, whereas mathematics is concerned with abstract patterns that need not have any bearing on it.** However, the distinction stand debatable by many to this day. Another question one may ask is, "how is physics related to engineering?". This answer to this inquiry will be found as contents of this course evolve before you.

Past to Present

Since antiquity, people have tried to understand the behavior of matter. The questions such as, why unsupported objects drop to the ground, why different materials have different properties, and so on, boggled the minds of our world's early civilizations and educators. Another mystery included the character of the universe, such as the form of the Earth and the behavior of celestial objects such as the Sun and the Moon. Several theories were proposed; most of them were incorrect, but this is part of the nature of the scientific enterprise, and even modern theories of quantum mechanics and relativity are merely considered "theories that have yet to be broken". Physical theories in antiquity were largely supported by philosophical terms, and not often verified by systematic experimental testing.

Typically, the behaviour and nature of the world was explained by invoking the actions and will of gods. Around 200 BC, many Greek philosophers began to propose that the world could be understood as the result of natural processes. Many also challenged traditional ideas presented in mythology, such as the origin of the human species (anticipating the ideas of Charles Darwin), although this falls into the history of biology, not physics. The atomists attempted to characterize the nature of matter, which anticipated work in our present day.

Due to the absence of advanced experimental equipment such as telescopes, standard weight measurements, and accurate time-keeping devices, experimental testing of many such ideas was impossible or impractical. There were exceptions: for instance, the Greek thinker Archimedes derived many correct quantitative descriptions of mechanics and also hydrostatics when he noticed that his own body displaced a volume of water while he was getting into a bath one day. Another remarkable illustration was that of Eratosthenes, who deduced that the Earth was a sphere, and accurately calculated its circumference using the shadows of vertical sticks to measure the angle between two widely separated points on the Earth's surface (locally). Greek mathematicians also proposed calculating the volume of objects such as cones and spheres by dividing them into very thin disks and adding up the volume of each disk - anticipating the invention of integral calculus by almost two millennia.

[Modern knowledge of these early ideas in physics, and the extent to which they were experimentally examined, is quite arbitrary. Nearly all direct record of these ideas was lost when the Library of Alexandria was destroyed, around 400 AD. Perhaps the most remarkable idea we know of from this era was the deduction by Aristarchus of Samos that the Earth was a planet that revolved around the Sun once a year, and rotated on its axis once a day (accounting for the seasons and the cycle of day and night), and that the stars were other, very distant suns which also possessed their own accompanying planets.

The discovery of the Antikythera mechanism points to a detailed understanding of movements of these astronomical objects, as well as a use of gear-trains that pre-dates any other known civilization's utilization of gears. The **Antikythera mechanism** is an ancient artifact believed to be an early clockwork mechanism that was discovered in a shipwreck off the Greek island of Antikythera dated to about 87 BC. The wreck was discovered in 1900 at a depth of about 140 feet (40 meters), and many statues and other works were retrieved from it by sponge divers. On May 17, 1902 archaeologist Spyridon Stais noticed that one of the pieces of rock had a gear wheel embedded into it.

The mechanism is the oldest known surviving geared mechanism, made from bronze in a wooden frame, and has intrigued historians of science, engineering, and technology since its discovery. The most commonly accepted theory of its function is that it was a type of "analog computer" designed to track the movements of heavenly objects. Recent working reconstructions of the device support this analysis. The device is all the more impressive for its use of a differential gear, which was previously believed to have been invented in the 13th century AD. In mechanical engineering, a **clockwork** is either a lightweight mechanical linkage, especially one involving multiple axles, or a complete mechanical device whose functioning relies on internal clockwork (in the preceding sense), especially where muscular effort is the sole source of operating power.

An early version of the steam engine, Hero's aeolipile was only a curiosity which did not solve the problem of transforming its rotational energy into a more usable form, not even by gears. The Archimedes screw is still in use today, to lift water from rivers onto irrigated farmland. The simple machines were unremarked, with the exception (at least) of Archimedes' elegant proof of the law of the lever. Ramps were in use several millennia before Archimedes, to build the Pyramids.

Regrettably, this period of inquiry into the nature of the world was eventually stifled by a tendency to accept the ideas of eminent philosophers, rather than to question and test those ideas. Pythagoras himself is said to have tried to suppress knowledge of the existence of irrational numbers, discovered by his own school, because they did not fit his number mysticism. For one thousand years following the destruction of the Library of Alexandria, Ptolemy's (not to be confused with the Egyptian Ptolemies) model of an Earth-centred universe with planets moving in perfect circular orbits was accepted as absolute truth.]

Ref:

<http://www.glenbrook.k12.il.us/gbssci/phys/Class/BBoard.html>

http://en.wikipedia.org/wiki/Main_Page

II. Algebra & Geometry Review

Ref: Problem Solving - Geometry Curriculum PREP I
<http://www.grc.nasa.gov/WWW/K-12/aerores.htm>
<http://www.glenbrook.k12.il.us/gbssci/phys/Class/BBoard.html>
http://en.wikipedia.org/wiki/Main_Page

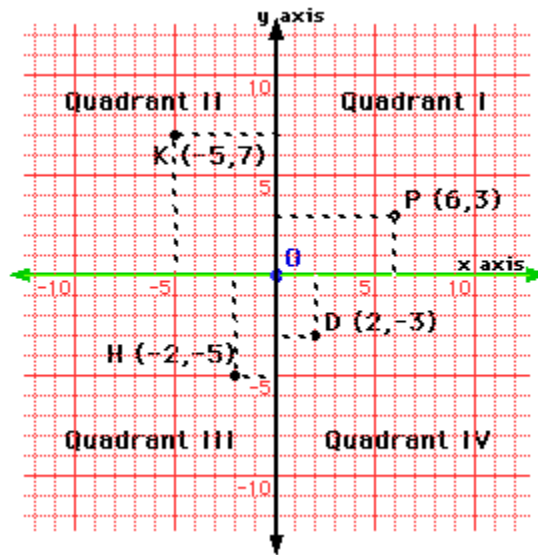

Terms & Definitions:

CARTESIAN PLANE (Red Grid)

A two dimensional space made up of points which can be identified by their distance relationship to the origin, the X-axis and the Y-axis. Also referred to as the Coordinate Plane.

AXES (Green & Black Lines)

A array of reference lines used in a graph or coordinate system.

X-AXIS (Green Line)

The horizontal number line in the coordinate system consisting of zero, negative, and positive numbers.

Y-AXIS (Black Line)

The vertical number line in the coordinate system consisting of zero, negative, and positive numbers.

ORDERED PAIR

A pair of numbers (X - coordinate, Y - coordinate) indicating the position of a point in the Cartesian Plane, for instance D (2,-3), a positive 2 x-value and a negative 3 y-value.

In the graph below, each point can be represented by a unique pair of numbers called an ordered pair. The Point A is 1 line to the right (Positive) and 5 lines up (Positive). So the Point A is represented by (1,5). All points in Quadrant I have two positive values, A(1,5) or D(2,2). All points in Quadrant II have a negative X-value and a positive Y-value, E(-1,3).

All points in Quadrant III have two negative values, B(-2,-1) or C(-3,-3). All points in Quadrant IV have a positive x-value and a negative y-value, (1,-3).

COORDINATES

A set of numbers that define the position of a point, or a set of points. For 2-D, each point has an X-coordinate and a Y-coordinate, while for 3-D each point has an (X,Y,Z) coordinates.

ORIGIN (Blue Point)

A fixed point from which measurements are taken. The origin (Point O) has coordinates (0,0) and is found at the point of intersection between the x-axis and the y-axis.

QUADRANTS

The four regions formed by the intersection of the X-axis and the Y-axis. Quadrant I : (+,+), Quadrant II : (-,+), Quadrant III : (-,-), Quadrant IV : (+,-), for all point values.

Collinearity:

COLLINEAR POINTS

A series of points which lie on a straight line. Any two points are collinear because there is a straight line that passes through both, thus we often determine if three or more points are collinear. By inspection, can you determine which points are collinear on the graph below?

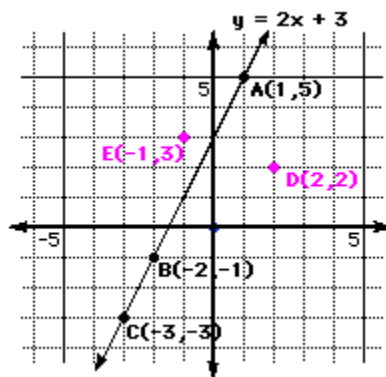

NON COLLINEAR POINTS

Opposite of Collinear Points – A series of points that do not lie on the same line. Example: Points A, B and E are non-collinear.

Determining Collinearity

For a point to be on a line it must 'balance', hence we solve the equation. For instance, the equation $y = 2x + 3$ expresses a line. If a point lies on this line then it will satisfy the equation.

Does B(-2,-1) lie on the line $y = 2x + 3$?

Substitute $x = -2$ & $y = -1$

$-1 = 2(-2) + 3$ which simplifies to $-1 = -1$

Therefore (-2,-1) satisfies the equation $y = 2x + 3$.

Does D(2,2) lie on the line $y = 2x + 3$?

Substitute $x = 2$ & $y = 2$

$2 = 2(2) + 3$ which simplifies to $2 \neq 7$

Therefore (2,2) DOES NOT satisfy the equation $y = 2x + 3$.

Right Triangles

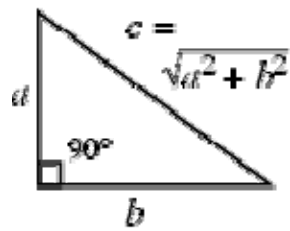

*general right
triangle*

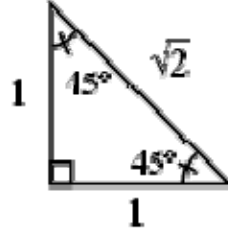

*isosceles right
triangle*

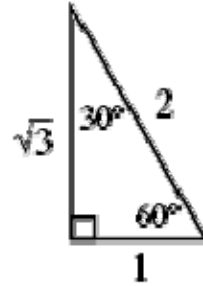

*30-60-90°
triangle*

A triangle with an angle of 90° ($\pi / 2$ radians). The sides a , b , and c of such a triangle satisfy the Pythagorean theorem

$$a^2 + b^2 = c^2, \tag{1}$$

where the largest side is conventionally denoted c and is called the hypotenuse. The side lengths (a,b,c) of a right triangle form a so-called Pythagorean triple. A triangle that is not a right triangle is sometimes called an oblique triangle. Special cases of the right triangle include the isosceles right triangle (middle figure) and 30-60-90 triangle (right figure).

For any three similar shapes of area A_i on the sides of a right triangle,

$$A_1 + A_2 = A_3, \tag{2}$$

which is equivalent to the Pythagorean theorem.



Sine – Cosine – Tangent

Very Basic Trigonometry

Glenn
Research
Center

Terminology:

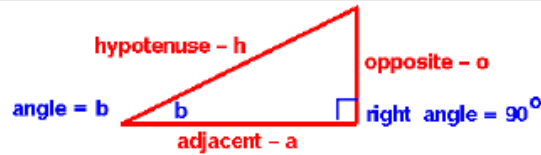

Definitions:

Assign a name to the **ratio** of the length of the sides of a right triangle

Sine:
 $\sin(b) = \frac{o}{h}$

Cosine:
 $\cos(b) = \frac{a}{h}$

Tangent:
 $\tan(b) = \frac{o}{a}$

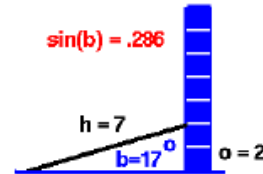
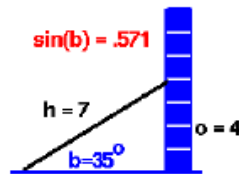
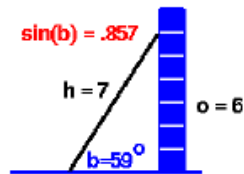

The value of each ratio depends only on the size of the angle.

At its purest, this is what science is all about. Observations are made of how many aspect of the universe work in harmony and measurements are made to attach numbers to these observed events. Finally, a theory is invented that explains these numbers. What the theory allows us to do is to calculate the results of experiments, which have not been performed yet. Often, we call this step in the scientific approach a hypothesis or prediction. A *theory* is tested by comparing its predictions to yet another observation. If there is agreement between the predictions of the theory and experimental results over a long time with multiple experiments, eventually we accept that theory one of the many "laws of nature", which govern the works of our universe. In the course of the verification, or even later after a theory has achieved "law" status, if a verifiable experiment comes up with a discrepancy between the theory's prediction and experimental observation, we go back and scrap the theory or modify it to cover the new observations. This cycle of theory and test boils down to the pursuit of truth. The pursuit of objective truth, truth that is verifiable by anyone willing to expend the effort, has been and is the most productive activity in which humankind has ever engaged.

For us to participate in scientific discovery, we need to be solidly grounded in the basics. That is the purpose of this course on mechanics. There are a few fundamental concepts we need to nail down before we begin toying with some of the laws of nature that were established by others. And, we must really understand those laws before we can begin to think about extending the scientific process I described in the previous paragraph.

III. Measurement and Data Analysis

An internationally agreed upon standard system of units is needed to measure and represent a wide variety of physical quantities. Scientists have accepted the **SI system** for this purpose. The **fundamental units of measurement** are: length (meter), time (second), mass (kilogram), electric current (ampere), temperature (degree kelvin), luminous intensity (candela), and the amount of substance (mole). You may find that some resources also refer to fundamental units as "basic" units or "base" units. It is wise to adopt one usage and apply it consistently.

Derived units are combinations of the fundamental units. Many of the units in the SI system are based on powers of ten for simplicity in conversion. The **order of magnitude** of a number is the value of the number when rounded to the nearest power of ten. The order of magnitude of a number in scientific notation should be rounded up if the mantissa is larger than 3.16. ($10^{0.5} = 3.16$). **Prefixes** are used in the SI system to serve as multipliers of fundamental and derived units. All measurements include a value and a unit. Some also require a direction. **Scientific notation** enables very large and very small numbers to be expressed conveniently. Every measured quantity contains **uncertainty**. Uncertainty is usually expressed either in absolute terms or as a percentage. Measured quantities should be expressed to the number of **significant figures** which best represent the accuracy of the measurement. When arithmetic operations are performed on measured quantities, the resulting answers should be expressed to an appropriate number of significant figures. In many experiments, measurements are taken of two or more variables to search for patterns or relationships, which govern the way things behave. Various techniques are used in physics to gather and interpret data. Data that is

arranged in tables and then plotted on graphs can assist in the interpretation of those data. Computers are useful tools in manipulating and analyzing data. The shape of a curve on a graph may help to suggest a relationship between variables. Reading data from graphs is essential in interpreting numeric information. **Interpolation** and **extrapolation** are useful in interpreting graphical information.

Learning Outcomes

Students will increase their abilities to:

1. Express physical quantities using a value, appropriate SI units, and (if necessary) direction.
2. Recognize the advantages of the SI system of measurement.
3. Distinguish between fundamental units and derived units.
4. Demonstrate the correct use of the SI system of measurement.
5. Recognize the limited accuracy of measured quantities.
6. Express numbers in scientific notation.
7. Express numerical information to the correct number significant figures.
8. Determine the order of magnitude of physical quantities.
9. Collect experimental data.
10. Graph numeric information.
11. Interpret information from a graph.
12. Extrapolate and interpolate graphical information.

Teaching Suggestions, Activities and Demonstrations

1. It is important to teach this topic in the context of experimental activities. There is no universal agreement on this, but many experienced physics teachers find doing so to be more effective than trying to teach this topic in an isolated manner. Emphasize key concepts relating to measurement and data analysis during those timely moments when they are most relevant to the learners.
2. Arrive at some agreement with other science teachers in your school about the use of significant figures and uncertainties of measurement. Students are often confused by the lack of consistency in the way these topics are handled. Different resources may have a different set of rules for expressing the uncertainty of measurement. Sometimes resource materials are not even consistent with the way significant figures are handled. Answers to problems may not be stated to the correct number of significant figures. Differences also appear in the way these topics are handled in physics and chemistry. See the following suggestion as well.
3. Students often have difficulty determining the correct number of significant digits resulting from an addition or subtraction operation. Stress that the result is given to the least number of significant **decimal places**, not to the least number of significant figures, as it is in multiplication and division.

For instance:

$$\begin{array}{r} 1.234 \quad (4 \text{ significant figures}) \\ +0.026 \quad (2 \text{ significant figures}) \\ \hline 1.260 \quad \text{The sum has } 4 \text{ significant figures.} \end{array}$$

4. It is not necessary to stress the conversion to and from non-SI units. Occasionally though, it may be useful, and even desirable, to show students how this is done. There are many practical instances when this has to be done. Students should not be expected to have to memorize conversion figures. Instead, they should be able to look them up as they are needed.
5. Derived units can be checked for their feasibility with other derived units by comparing their **dimensions**. For example, the unit km/h for speed combines the dimensions of distance {d} and time {t} as {d / t}. Other derived units that combine the dimensions of distance and time in the same way, such as m/s or cm/min, could also be units of speed. Also, for equations to balance properly, they must be able to be shown using the same dimensions on both the left and the right sides.

Units:

Units are the basis of all measurements. Units are just as important as the numbers we calculate, and without proper units these numbers are meaningless. Does anyone recall how one of the Mars satellites crashed? The satellite was designed by a variety of countries, some of which use the Metric system as opposed to our English system. While the satellite was in flight, engineers forget to change their units when commanding the spacecraft with numerical parameters. Consequently, the satellite crashed. We should all know that 500 mph does not equal 500 kph.

Length of Volume Equivalents:

Length

The standard unit of length in the metric system is the meter. Other units of length and their equivalents in meters are as follows:

1 millimeter = 0.001 meter
1 centimeter = 0.01 meter
1 decimeter = 0.1 meter
1 kilometer = 1000 meters

We abbreviate these lengths as follows:

1 millimeter = 1 *mm*
1 centimeter = 1 *cm*
1 meter = 1 *m*
1 decimeter = 1 *dm*
1 kilometer = 1 *km*

Volume

The standard unit of volume in the metric system is the liter. One liter is equal to 1000 cubic centimeters in volume. Other units of volume and their equivalents in liters are as follows:

1 milliliter = 0.001 liter
1 centiliter = 0.01 liter
1 deciliter = 0.1 liter
1 kiloliter = 1000 liters

From these units, we see that 1000 milliliters equal 1 liter; so 1 milliliter equals 1 cubic centimeter in volume.

We abbreviate these volumes as follows:

1 milliliter = 1 *ml*
1 centiliter = 1 *cl*
1 deciliter = 1 *dl*
1 liter = 1 *l*
1 kiloliter = 1 *kl*

Mass

The standard unit of mass in the metric system is the gram. Other units of mass and their equivalents in grams are as follows:

$$\begin{aligned}1 \text{ milligram} &= 0.001 \text{ gram} \\1 \text{ centigram} &= 0.01 \text{ gram} \\1 \text{ decigram} &= 0.1 \text{ gram} \\1 \text{ kilogram} &= 1000 \text{ grams}\end{aligned}$$

We abbreviate these masses as follows:

$$\begin{aligned}1 \text{ milligram} &= 1 \text{ mg} \\1 \text{ centigram} &= 1 \text{ cg} \\1 \text{ decigram} &= 1 \text{ dg} \\1 \text{ gram} &= 1 \text{ g} \\1 \text{ kilogram} &= 1 \text{ kg}\end{aligned}$$

Time

The following conversions are useful when working with time:

$$\begin{aligned}1 \text{ minute} &= 60 \text{ seconds} \\1 \text{ hour} &= 60 \text{ minutes} = 3600 \text{ seconds} \\1 \text{ day} &= 24 \text{ hours} \\1 \text{ week} &= 7 \text{ days} \\1 \text{ year} &= 365 \frac{1}{4} \text{ days (for the Earth to travel once around the sun)}\end{aligned}$$

In practice, every three calendar years will have 365 days, and every fourth year is a "leap year", which has 366 days, to make up for the extra quarter day over four years. The years 1992, 1996, 2000, and 2004 are all leap years. This gives us a total of 52 complete 7 day weeks in each calendar year, with 1 day left over (or 2 in a leap year).

The International system (SI) is a comprehensive and practical system of units of measure of all physical quantities for technical, scientific and general use. The unit of measurement for every physical quantity is derived from, and described in terms of, one or more base units. The seven base units are the meter (m), kilogram (kg), second (s), ampere (A), Kelvin (K), candela (cd) and mole (mol). Larger or smaller multiples of these units of more convenient size are obtained by combining the unit with an appropriate prefix selected from a specific series.

Decimals in measurement

<u>Prefix</u>	<u>Multiply by</u>
milli-	0.001
centi-	0.01
deci-	0.1
deka-	10
hecto-	100
kilo-	1000

Prefixes		
Name	Prefix	Factor
yocto	y	10^{-24}
zepto	z	10^{-21}
atto	a	10^{-18}
femto	f	10^{-15}
Pico	p	10^{-12}
Nano	n	10^{-9}
micro	μ	10^{-6}
milli	m	10^{-3}
centi	c	10^{-2}
Deci	d	10^{-1}
Kilo	k	10^3
mega	M	10^6
Giga	G	10^9
tera	T	10^{12}
Peta	P	10^{15}
exa	E	10^{18}
Zeta	Z	10^{21}
Yota	Y	10^{24}

Base Units		
Physical Quantity	Unit	Symbol
length	metre	m
area	square metre	m^2
volume	cubic metre	m^3
capacity	litre (non SI unit)	L
mass	gram	g
mass	tonne (non SI unit)	t
density	kilogram per cubic metre	kg/m^3
time	seconds	s
velocity	metre per second	m/s
acceleration	metre per second squared	m/s^2
angular velocity	radians per second	rad/s
temperature	kelvin	K
force	newton	N ($kg \cdot m/s^2$)
pressure	pascal	Pa (N/m^2)
energy	joule	J (N.m)
power	watt	W (J/s)
potential difference	volt	V
electric current	ampere	A
electric quantity	coulomb	C (A.s)

potential difference, electromotive force	volt	V (W/A)
electric field strength	volt per meter	V/m
electric resistance	ohm	\dot{U} (V/A)
capacitance	farad	F (A.s/V)
magnetic flux	weber	Wb (V.s)
inductance	henry	H (V.s/A)
magnetic flux density	tesla	T (Wb/m ²)
magnetic field strength	ampere per meter	A/m
frequency	hertz	Hz
chemical substance	mole	mole
plane angle	radian	rad
entropy	joule per kelvin	J/K
specific heat capacity	joule per kilogram kelvin	J/(kg.K)
thermal conductivity	watt per meter kelvin	W/(m.K)
radiant intensity	watt per steradian	W/sr

Ref: <http://www.mathleague.com/help/metric/metric.htm>

Quantities

First let's think about physical quantities. These are the building blocks in terms of which the laws of nature are expressed. Among these are length, mass and time and a lot of others derivable from these. Examples of quantities that may be derived *from distance, mass and time are force, velocity, momentum, energy and acceleration.*

Those physical quantities, which are distinctly associated with an object, like mass for example, are called *properties* of the object. As we deal with these quantities I will try to always be clear on exactly which I am working with. There is nothing magic by the way about the choice of length, mass and time as the fundamental quantities. We could have begun with others and derived these.

Now if we are to determine useful things about objects in terms of the physical quantities, we must agree on the units of measure of these quantities. Units of measure allow us to answer the "how much" questions. How much length? How much mass? How much time? I will mainly stick to the International System (SI) which has become the most commonly accepted for scientific work. In this system of units the standards are: length - meter, mass - kilogram and time - second. If you insist on using a furlong, stone weight, fortnight system you will probably end up spending a lot of time doing unit conversions.

Mass vs. Weight

The concept of weight and volume were formed out of the necessities of commerce in earliest times. Measure, the quantity of matter, indicates the amount of matter that exists in a material object. This is known as one of the most basic notions in physics, the concept of mass (m). Historically, our society has understood weight to be the "downward" force exerted by an object at the surface of the Earth, which was assumed to be constant.

Mechanics

Mechanics is the study of objects in motion so we are going to need a way to describe both objects and motion. At this stage of the story we are going to limit ourselves to objects that may be regarded as particles. A particle is a bit of matter whose size is small enough relative to our observations that its dimensions may be neglected. For example the Earth might be considered a particle if we were studying its orbit around the Sun, but not if we want to know anything about its rotation about its axis. The nucleus of an atom might be a particle in an experiment on elastic scattering, but not in considering nuclear fission.

Under the restriction that our objects are going to be particles, the only property related to mechanics an object can have is mass. This means that to describe an object only requires that its mass be specified. Any other property you can imagine, let's say density for example, requires that the object have some size.

Now let's examine what we mean when we say something is in motion. We are all familiar with motion of birds and cars move. All we need to do is to quantify this everyday experience a bit to apply it to mechanics. Motion always implies the passage of time. Let's define two specific times called early and late. If an object is found at a different position at $\text{time}=\text{late}$ than where it was at $\text{time}=\text{early}$ then we say movement took place. If there is still a difference in position when time late is as close to time early as we can imagine, then we say the object is in motion.

Dimensions

The word "dimension" showed up recently in the sense of the extent of an object. The other sense of that word, dimension, has to do with the nature of the space being considered. For our purposes, neglecting Einsteinian relativity, we live in a three dimensional space. The surface of a sheet of paper or a computer screen might represent a space of two dimensions. A single line, like the number line, represents a space of one dimension.

The words "infinite" and "infinitesimal" also need a bit of explanation. I would like to have infinite mean big enough so that bigger makes no practical difference. An infinite distance, under this definition, might be 1 centimeter if we are discussing the gravitational attraction between two molecules. Let us agree that infinitesimal is small enough that smaller doesn't matter. Like the radius of the Earth in considering planetary orbits.

Another fundamental concept in mechanics is that of an observer and the observer's frame of reference. Frequently we give no thought to the observer or the reference frame in everyday life because we ourselves are doing the observing and our frame of reference is a system of measure relative to the location of our eyes. For example we judge location by how far left, how far up and how far away. We determine motion by noticing a change in location. In this course I will be asking you to imagine experiments in which the observer's reference frame may be other than your own.

As mentioned, intuitively we detect motion as a change in **position** over time. In mechanics it is the same but we need more than "eyeball" precision in determining position. We will quantify the position of particles by measuring from a fixed point in our reference frame to the particle. The fixed point from which measurements are made is called the "origin" of the reference frame. There are two convenient ways to measure the position of a particle. One is to measure along the dimensions of the space in which our reference frame is constructed. The other is to measure the distance and direction from the origin to the particle.

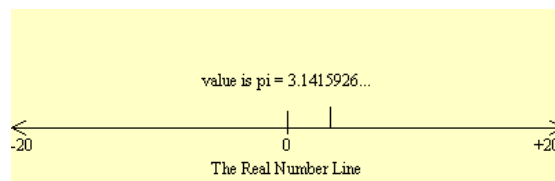

Suppose we wish to measure the position of a particle, which could only move in a straight line. We would choose a one-dimensional space in which to study the motion since the other possible dimensions do not add any intelligence. The reference frame would then be a real number line called an axis and the position would be just how many length units the particle was from the origin. In this one- dimensional model, the two ways of measuring position are identical. The

particle must lie exactly on the one axis of the reference frame so the measure along the dimension of the reference frame is the distance from the origin to the particle. The Real Number Line display seen previously is an example of a one dimensional reference frame.

Now consider a case where a particle is constrained to stay in a plane, that is on a flat surface. Here we would choose a two dimensional space in which to study the motion. We choose the reference frame to be two number lines (axes), perpendicular to each other with zero as their common point. Making the lines perpendicular is a trick to simplify the mathematics but any two non-parallel lines could serve. Any set of lines that could serve as axes for a reference frame is said to "span" the space in which the reference frame is constructed. Traditionally the horizontal axis is labeled the x-axis and the vertical the y axis.

Working in two dimensions, we now have distinct ways of locating a particle. One is to measure its position along one of the axes, then measure its position parallel to the second axis. That pair of numbers, called the coordinates of the particle uniquely establish its position. One way of designating the coordinates is to place the two numbers in parentheses like (a, b) . This notation is called an ordered pair. The x-coordinate (a) is always first, then separated by a comma the y coordinate (b).

The other way of locating a particle is to measure the distance from the origin to the particle and measure the angle of that line from the horizontal axis so that we have a magnitude and direction. Run the Reference Frame 2D display to see these concepts in action.

- Chapter 2 -

- I. Momentum & Inertia
- II. Scalars & Vectors
- III. Forces
 - a. Resultant Forces
 - b. Component Forces
 - c. Centripetal vs. Centrifugal
- IV. Rotational Forces
 - a. Torque (Moment)

Ref:

<http://www.glenbrook.k12.il.us/gbssci/phys/Class/BBoard.html>

http://en.wikipedia.org/wiki/Main_Page

<http://www.grc.nasa.gov/WWW/K-12/aerores.htm>

I. Momentum

Momentum is a commonly used term in sports. A team that has the momentum is on *the move* and is going to take some effort to stop. A team that has a lot of momentum is really *on the move* and is going to be *hard to stop*. Momentum is a physics term; it refers to the quantity of motion that an object has. A sports team, which is "on the move", has the momentum. If an object is in motion ("on the move") then it has momentum.

Momentum can be defined as "mass in motion." All objects have mass; so if an object is moving, then it has momentum - it has its mass in motion. The amount of momentum, which an object has, is dependent upon two variables: how much *stuff* is moving and how fast the *stuff* is moving. Momentum depends upon the variables mass and velocity. In terms of an equation, the momentum of an object is equal to the mass of the object times the velocity of the object.

$$\text{Momentum} = \text{mass} \times \text{velocity}$$

In physics, the symbol for the quantity momentum is the small case "p" or "M"; thus, the above equation can be rewritten as:

$$p = m \times v = M$$

where m = mass and v=velocity.

The equation illustrates that momentum is directly proportional to an object's mass and directly proportional to the object's velocity.

The units for momentum would be mass units times velocity units. The standard metric unit of momentum is the kg*m/s. While the kg*m/s is the standard metric unit of momentum, there are a variety of other units which are acceptable (though not conventional) units of momentum; examples include kg*mi/hr, kg*km/hr, and g*cm/s. In each of these examples, a mass unit is multiplied by a velocity unit to provide a momentum unit. This is consistent with the equation for momentum.

Momentum is a **vector quantity**. To fully describe the momentum of a 5-kg bowling ball moving westward at 2 m/s, you must include information about both the magnitude and the direction of the bowling ball. It is not enough to say that the ball has 10 kg*m/s of momentum; the momentum of the ball is not fully described until information about its direction is given. The direction of the momentum vector is the same as the direction of the velocity of the ball. In a previous unit, it was said that the direction of the velocity vector is the same as the direction which an object is moving. If the bowling ball is moving westward, then its momentum can be fully described by saying that it is 10 kg*m/s, westward. As a vector quantity, the momentum of an object is fully described **by both magnitude and direction.**

From the definition of momentum, it becomes obvious that an object has a large momentum if either its mass or its velocity is large. Both variables are of equal importance in determining the momentum of an object. Consider a Mack truck and a roller skate moving down the street at the same speed. The considerably greater mass of the Mack truck gives it a considerably greater momentum. Yet if the Mack truck were at rest, then the momentum of the least massive roller skate would be the greatest; for the momentum of any object, which is at rest is 0. Objects at rest do not have momentum - they do not have any "mass in motion." Both variables - mass and velocity - are important in comparing the momentum of two objects.

- The momentum equation can help us to think about how a change in one of the two variables might affect the momentum of an object. For instance, consider:

A 0.5-kg physics cart loaded with one 0.5-kg brick and moving with a speed of 2.0 m/s. The total mass of *loaded* cart is 1.0 kg and its momentum is 2.0 kg*m/s. If the cart was instead loaded with three 0.5-kg bricks, then the total mass of the *loaded* cart would be 2.0 kg and its momentum would be 4.0 kg*m/s. A doubling of the mass results in a doubling of the momentum.

Similarly, if the 2.0-kg cart had a velocity of 8.0 m/s (instead of 2.0 m/s), then the cart would have a momentum of 16.0 kg*m/s (instead of 4.0 kg*m/s). A *quadrupling* in velocity results in a *quadrupling* of the momentum. These two examples illustrate how the equation $p=(m)(v)$ serves as a "guide to thinking" and not merely a "recipe for algebraic problem-solving."

Inertia

Inertia = the resistance an object has to a change in its state of motion.

Galileo, the premier scientist of the seventeenth century, developed the concept of inertia. Galileo reasoned that moving objects eventually stop because of a force called friction. In experiments using a pair of inclined planes facing each other, Galileo observed that a ball will roll down one plane and up the opposite plane to approximately the same height. If smoother planes were used, the ball would roll up the opposite plane even closer to the original height. Galileo reasoned that any difference between initial and final heights was due to the presence of friction. Galileo postulated that if friction could be entirely eliminated, then the ball would reach exactly the same height.

Galileo further observed that regardless of the angle at which the planes were oriented, the final height was almost always equal to the initial height. If the slope of the opposite incline was reduced, then the ball would roll a further distance in order to reach that original height.

Isaac Newton built on Galileo's thoughts about motion. Newton's first law of motion declares that a force is not needed to keep an object in motion. Slide a book across a table and watch it slide to a rest position. The book in motion on the table top does not come to a rest position because of the *absence* of a force; rather it is the *presence* of a force - that force being the force of friction - which brings the book to a rest position. In the absence of a force of friction, the book would continue in motion with the same speed and direction – forever & ever! (Or at least to the end of the table top.) A force is not required to keep a moving book in motion; in actuality, it is a force that brings the book to rest.

Ref: <http://www.glenbrook.k12.il.us/gbssci/phys/Class/newtlaws/u2l1b.htm>

II. Scalars and Vectors

Physics is a mathematical science - that is, the underlying concepts and principles have a mathematical basis. Throughout this tutorial, you will encounter a variety of concepts which have a mathematical basis associated with them. While the emphasis will often be upon the conceptual nature of physics, there will also be considerable and persistent attention given to its mathematical aspect.

The motion of objects can be described by words - words such as distance, displacement, speed, velocity, and acceleration. These mathematical quantities which are used to describe the motion of objects can be divided into two categories. The quantity is either a vector or a scalar. These two categories can be distinguished from one another by their distinct definitions:

- **Scalars** are quantities which are fully described by a magnitude alone.
- **Vectors** are quantities which are fully described by both a magnitude and a direction.

The remainder of this lesson will focus on several examples of vector and scalar quantities (distance, displacement, speed, velocity, and acceleration). As you proceed through the lesson, give careful attention to the vector and scalar nature of each quantity. Throughout these lessons, when you are introduced to new mathematical quantities, the discussion will often begin by identifying the new quantity as being either a vector or a scalar.

2-D Vectors

Finally think about a particle that is free to move in three dimensions. To span a three dimensional space we need three axes for our reference frame. Again we will make them all share a common zero and be mutually perpendicular. Sometimes you may see the word "orthogonal" to describe lines that are all perpendicular to each other. Again we could locate a particle by giving its coordinates (a,b,c) or by giving the distance and direction from the origin of the reference frame. Note that the direction in three dimensions now requires two angles, a latitude and longitude for example. As a general principle, it will require as many numbers as there are dimensions in our space to specify the location of a particle. The number of numbers required to specify the position of any object, not just a particle is called the "degrees of freedom" of that object.

Up to two dimensions, the representation of the reference frame on the monitor screen posed no problems. Once we add the third dimension, the two dimensional nature of the screen gets in the way. Some imagination will be required to see this flat display as three-dimensional. Picture the situation like this. Begin with the x and y axis as described in the two dimensional case. Now suppose that instead of the axes lying on the surface of the screen, the screen is a window through which you look to see the reference frame axes somewhere behind the screen. Also imagine that there is another invisible horizontal axis parallel to the screen through the center of the volume of space outlined in the display, about which we may rotate the image. We will call this the pitch axis.

Next imagine that I draw a third reference frame axis, with its positive end sticking straight toward the screen. Call that axis the z-axis. Since the z-axis is sticking straight toward you, you cannot see it until we rotate the frame about the pitch

axis. In fact we will rotate it around both the pitch axis and the newly created z-axis in the next display. The angle through which an object is rotated about the pitch axis is called the pitch angle, about the z-axis, the yaw angle.

The choice of which axis is x, which is y and which is z is sometimes a bone of contention among different branches of science and always a point of confusion if not spelled out. What we will use is called a right-handed reference frame. That means if you hold the thumb, fore finger and middle finger of your right hand more or less at right angles to each other, your thumb will point along the positive x axis, your fore finger will point along the positive y axis and your middle finger will point along the positive z-axis. Whatever orientation you hold your hand in, the relationships among the axes will be the same.

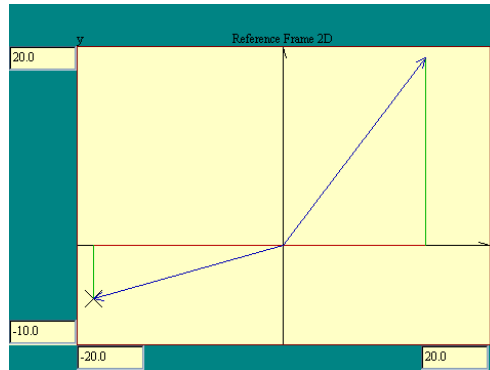

Problem Solving - Geometry Curriculum PREP I
Ref: <http://www.glenbrook.k12.il.us/gbssci>

3-D Vectors

We have been observing the reference frames we have talked about from somewhere outside the frame itself. If the reference frame was really a solid object suspended in space, we could walk around it and presumably view it from above or below. We may find it convenient to look at frames that way or we may wish to view objects as if we were in the frame ourselves. Remember we created the idea of a reference frame so that we could determine where things were located and many times we want to know where they are relative to us, the observer. If we do choose to look at a reference frame from the outside, we may want to re-orient the frame so as to see objects in the frame from various perspectives.

Now for one other problem which comes up when looking at three dimensional reference frames. In one and two dimensions the screen cursor served to point out locations in the reference frame. In three dimensions only two of the axes can lie in the plane of the screen where the cursor is. And depending on the orientation of the frame in the monitor, none of the axes must lie in that plane. So the cursor is unavailable for us to use in marking positions. To identify a point in a three dimensional frame we will have to specify the distance along each of the axes to the point.

We have spent a lot of time describing how to locate objects in spaces of 1, 2 or 3 dimensions. Much of our work will be done using a two dimensional representation, even if we are considering a single dimension of space. That will allow us to plot position as a function of time. In fact we have been a little fast and loose with the idea of locating an object. Not only must we specify x, y and z, but also when. We will speak more about this idea later.

Vector Arithmetic

[In measuring position by distance and direction we used a line with an arrowhead on it. This representation of position is called a "vector". Just as there is an arithmetic of numbers, there is an arithmetic of vectors. We are going to be interested in motion of particles and have already said that motion is change in position over time. To get a change in a number it is customary to subtract the initial value from the final. To get a change in position we will use the same technique, subtracting the starting position from the ending. So how would you subtract two positions? Well it is most convenient to think of the positions as vectors to do this.

We have identified a line segment with direction and magnitude as a vector. If \mathbf{V} is a particular vector, then $|\mathbf{V}|$ symbolizes its magnitude. Quantities that can be specified by a magnitude only are called "scalar" quantities to distinguish them from vectors. Since scalar quantities are just numbers, they may be added in the ordinary way. An addition operation is also defined for vectors. Adding a mixture of vectors and scalars is not defined.

To add vectors there are two techniques available, geometric addition and algebraic addition. Both yield the same result. The choice of which technique to use in adding vectors depends on the application and is a matter of convenience. First we will discuss geometric vector addition. Since a vector is defined by its magnitude and direction, changing its location in our reference frame without changing its direction or magnitude leaves it the same vector. We are free to relocate a vector anywhere in our space where we find it convenient. To add vectors geometrically we just place the tail of one at the head of the other. The sum then is a vector from the tail of the first vector to the head of the last. Run the Geometric Vector Addition display to see how this works.

The algebraic addition of vectors involves simply adding up the like components of the vectors. Imagine a vector with its tail at the origin. The "scalar components" of that vector are just the coordinates of the head of the vector. Remember that the coordinates were the distances along each axis which defined the position of the head of the vector. To add two vectors, add all the x components together and all the y components. The algebraic addition of vectors works because the sums of the components are the components of the sum.

To break a vector down into its components is called vector resolution. What that means is that we will resolve a vector into its "vector components". I have already defined the scalar components of a vector as the coordinates of the head of the vector when its tail is at the origin. The vector components are the vectors lying along the axes that add up to the vector we are interested in. Run the Vector Resolution display to see an example in 3 dimensions. Just for variety we will use a 3 dimensional vector here. In general we will use the fewest number of dimensions needed to convey the desired information but I wanted to illustrate that vectors in 3 dimensions differ from 2 dimensional vectors only in that they involve an extra coordinate.

Since a vector along an axis has its direction fixed by definition, only its magnitude changes. That means we can uniquely define each component of a vector with just a number, knowing whether we are talking about the x, y or z component. Now, that we could also specify the position of a particle with the scalars that we called coordinates. There is an obvious relationship between the coordinates of a position and the components of the vector pointing to that position. They are numerically equal. Recognize that in vectors as in numbers, subtraction is just addition with the sign of the entity to be subtracted reversed. That of course brings up the question of what it means to have the sign of a vector reversed. To reverse the sign of a number we just multiply it by -1. To apply the same trick to a vector we must agree on what it means to multiply a vector by a scalar, in this case -1.]

The product of a scalar times a vector is a vector whose components are the components of the original vector, each multiplied by the scalar. Except for some special cases which I will cover soon, we will use bold letters to symbolize vectors. Run the Scalar Vector Multiplication display to see how this multiplication works. Verify that when the scalar multiplier is -1, the product vector has the same magnitude as the original and points the other way.

Now that we know how to multiply vectors by scalars we can modify our idea of vector components slightly. Consider a vector of **length 1**, in the direction of the x-axis. This is called the **unit vector**. There are also similar y and z unit vectors. Following tradition in these matters we will label the x unit vector (called "i" hat), the y unit vector ("j" hat) and the z unit vector ("k" hat). Now if we have a vector **V** with its head at coordinates (a,b,c) it can be expressed as the sum of three vectors:

$$\mathbf{a} + \mathbf{b} + \mathbf{c}.$$

The vector a^* is the product of the unit vector and the scalar component a. The vectors b^* and c^* are also the products of unit vectors and their corresponding scalar components. The three vectors, a^* , b^* and c^* are the vector components of **V**. The quantities a, b and c are the scalar components of **V** as well as the coordinates of head of the **V** vector. The unit vectors are the exception to the italicized rule. Run the Vector Components display to see the ideas of this paragraph illustrated.

Methods of adding vectors were discussed earlier in Lesson 1 of this unit. During that discussion, the head to tail method of vector addition was introduced as a useful method of adding vectors which are not at right angles to each other. Now we will see how that method applies to situations involving the addition of force vectors.

A force board (or force table) is a common physics lab apparatus that has three (or more) strings or cables attached to a center ring. The strings or cables exert forces upon the center ring in three different directions. Typically the experimenter adjusts the direction of the three forces, makes measurements of the amount of force in each direction, and determines the vector sum of three forces. (NOTE: This is the method used in the "Vectors Are a Snap" Lab.)

Suppose that a force board or a force table is used such that there are three forces acting upon an object (the object is the ring in the center of the force board or force table). In this situation, each of the three forces are acting in two-dimensions. A top view of these three forces could be represented by the following diagram.

<http://www.glenbrook.k12.il.us/gbssci/phys/Class/BBoard.html>

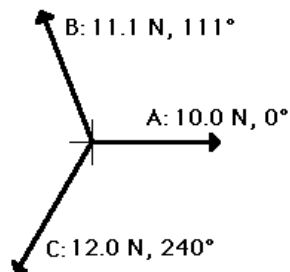

The goal of a force analysis is to determine the net force (and the corresponding acceleration). The net force is the vector sum of all the forces. That is, the net force is the resultant of all the forces; it is the result of adding all the forces as vectors. For the situation of the three forces on the force board, the net force is the sum of force vectors $A + B + C$.

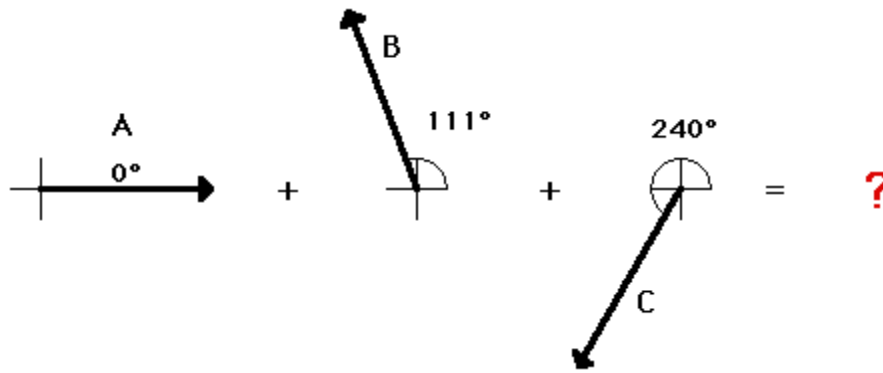

<http://www.glenbrook.k12.il.us/gbssci/phys/Class/BBoard.html>

One method of determining the vector sum of these three forces (i.e., the net force") is to employ the method of head-to-tail addition. In this method, an accurately drawn scaled diagram is used and each individual vector is drawn to scale. Where the head of one vector ends, the tail of the next vector begins. Once all vectors are added, the resultant (i.e., the vector sum) can be determined by drawing a vector from the tail of the first vector to the head of the last vector. This procedure is shown below. The three vectors are added using the head-to-tail method. Incidentally, the vector sum of the three vectors is 0 Newtons - the three vectors add up to 0 Newtons.

SCALE: 1 cm = 4 N

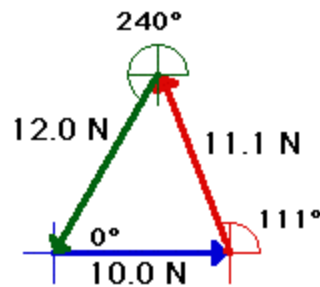

$$A + B + C = 0 \text{ N}$$

<http://www.glenbrook.k12.il.us/gbssci/phys/Class/BBoard.html>

The purpose of adding force vectors is to determine the net force acting upon an object. In the above case, the net force (vector sum of all the forces) is 0 Newtons. This would be expected for the situation since the object (the ring in the center of the force table) was at rest and staying at rest. We would say that the object was at equilibrium. Any object upon which all the forces are balanced ($F_{\text{net}} = 0 \text{ N}$) is said to be at equilibrium.

Quite obviously, the net force is not always 0 Newtons. In fact, whenever objects are accelerating, the forces will not balance and the net force will be nonzero. This is consistent with Newton's first law of motion. For example consider the situation described below.

An Example to Test Your Understanding

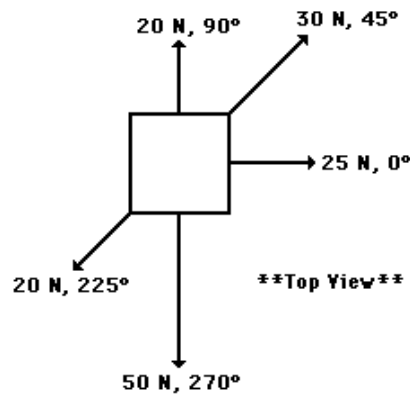

<http://www.glenbrook.k12.il.us/gbssci/phys/Class/BBoard.html>

A pack of five Artic wolves are exerting five different forces upon the carcass of a 500-kg dead polar bear. A top view showing the magnitude and direction of each of the five individual forces is shown in the diagram at the right. The counterclockwise convention is used to indicate the direction of each force vector. Remember that this is a top view of the situation and as such does not depict the gravitational and normal forces (since they would be perpendicular to the plane of your computer monitor); it can be assumed that the gravitational and normal forces balance each other. Use a scaled vector diagram to determine the net force acting upon the polar bear. Then compute the acceleration of the polar bear (both magnitude and direction).

The task of determining the vector sum of all the forces for the polar bear problem involves constructing an accurately drawn scaled vector diagram in which all five forces are added head-to-tail. The following five forces must be added.

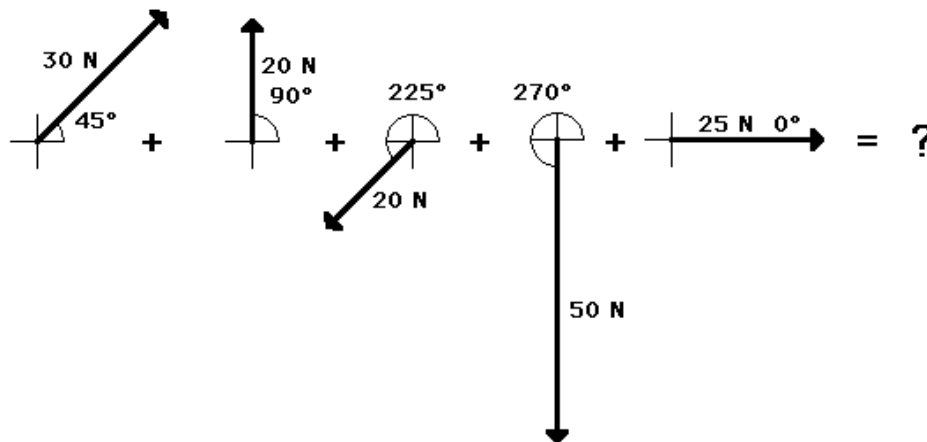

<http://www.glenbrook.k12.il.us/gbssci/phys/Class/BBoard.html>

Resultants

the parallelogram method

The **resultant** is the vector sum of two or more vectors. It is *the result* of adding vectors together. If displacement vectors A, B, and C are added together, the result will be vector R. As shown in the diagram, vector R can be determined by the use of an accurately drawn, scaled, vector addition diagram.

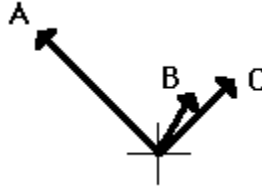

In all such cases, the resultant vector (whether a displacement vector, force vector, velocity vector, etc.) is the result of adding the individual vectors. It is the same thing as adding $A + B + C + \dots$. "To do $A + B + C$ is the same as to do R." As an example, consider a football player who gets hit simultaneously by three players on the opposing team (players A, B, and C). The football player experiences three different applied forces. Each applied force contributes to a total or resulting force. If the three forces are added together using methods of vector addition (discussed earlier), then the resultant vector R can be determined. In this case, to experience the three forces A, B and C is the same as experiencing force R. To be hit by players A, B, and C would result in the same force as being hit by one player applying force R. "To do $A + B + C$ is the same as to do R." Vector R is the same result as vector $A + B + C$!!

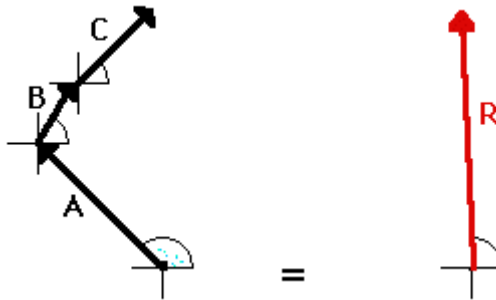

In summary, the resultant is the vector sum of all the individual vectors. The resultant is the result of combining the individual vectors together. The resultant can be determined by adding the individual forces together using vector addition methods.

<http://www.glenbrook.k12.il.us/gbssci/phys/Class/BBoard.html>

In summary, the resultant is the vector sum of all the individual vectors. The resultant is the result of combining the individual vectors together. The resultant can be determined by adding the individual forces together using vector addition methods.

Vector Components

A vector is a quantity which has magnitude and direction. Displacement, velocity, acceleration, and force are the vector quantities which we have discussed thus far in our course. In the first couple of units of our course, all vectors which we discussed were simply directed up, down, left or right. When there was a free-body diagram depicting the forces acting upon an object, those forces were directed in one dimension - up, down, left or right. When an object had an acceleration and we described its direction, it was directed in one dimension - up, down, left or right. Now in this unit, we begin to see examples of vectors which are directed in two dimensions - upward and rightward, northward and westward, eastward and southward, etc.

In situations in which vectors are directed at angles to the customary coordinate axes, a useful mathematical trick will be employed to transform the vector into two parts, with each part being directed along the coordinate axes. For example, a vector which is directed northwest can be thought of as having two parts - a northward and a westward part. A vector which is directed upward and rightward can be thought of as having two parts - an upward and a rightward part

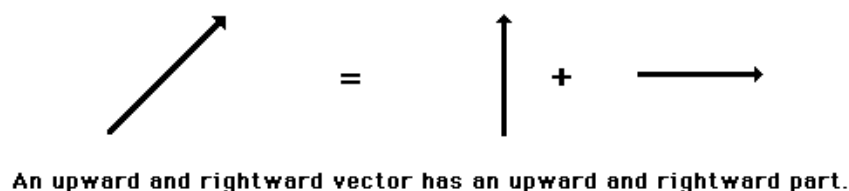
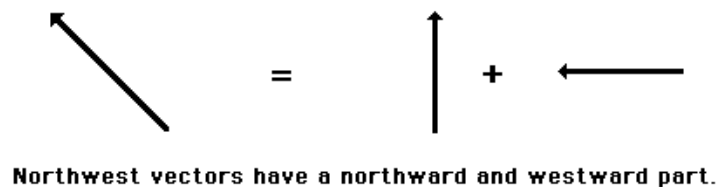

<http://www.glenbrook.k12.il.us/gbssci/phys/Class/BBoard.html>

Any vector directed in two dimensions can be thought of as having an influence in two different directions. That is, it can be thought of as having two parts. Each part of a two-dimensional vector is known as a component. The components of a vector depict the influence of that vector in a given direction. The combined influence of the two components is equivalent to the influence of the single two-dimensional vector. The single two-dimensional vector could be replaced by the two components.

Forces in Two Dimensions

Net Force Problems Revisited

This part of Lesson 3 focuses on net force-acceleration problems in which an applied force is directed at an angle to the horizontal. We have already discussed earlier in Lesson 3 how a force directed an angle can be resolved into two components - a horizontal and a vertical component. We have also discussed in an earlier unit that the acceleration of an object is related to the net force acting upon the object and the mass of the object (Newton's second law). We had used this principle to solve net force-acceleration problems in an earlier unit. Therefore, it is a natural extension of this unit to combine our understanding of Newton's second law with our understanding of force vectors directed at angles.

To begin, consider the situation below in which a force is directed at an angle to the horizontal. In such a situation, the applied force can be resolved into two components. These two components can be considered to replace the applied force at an angle. By doing so, the situation has been simplified into a familiar situation in which all the forces are directed either horizontally or vertically.

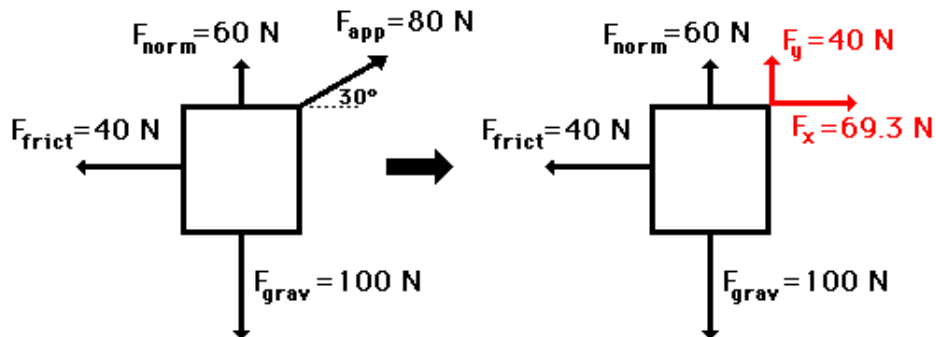

A force directed at an angle to the horizontal can be resolved into two components. Together, these two components are replacement of the single force.

<http://www.glenbrook.k12.il.us/gbssci/phys/Class/BBoard.html>

Once the situation has been simplified, the problem can be solved like any other problem. The task of determining the acceleration involves first determining the net force by adding up all the forces as vectors and then dividing the net force by the mass to determine the acceleration. In the above situation, the vertical forces are balanced (i.e., F_{grav} , F_y , and F_{norm} add up to 0 N), and the horizontal forces add up to 29.3 N, right (i.e., 69.3 N, right + 40 N, left = 29.3 N, right). The net force is 29.3 N, right and the mass is 10 kg ($m = F_{\text{grav}}/g$); therefore, the acceleration is 2.93 m/s/s, right.

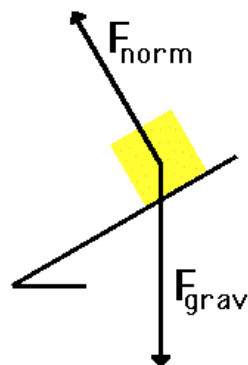

<http://www.glenbrook.k12.il.us/gbssci/phys/Class/BBoard.html>

Inclined Planes

An object placed on a tilted surface will often slide down the surface. The rate at which the object slides down the surface is dependent upon how *tilted* the surface is; the greater the *tilt* of the surface, the faster the rate at which the object will slide down it. In physics, a *tilted surface* is called an inclined plane. Objects are known to accelerate down inclined planes because of an unbalanced force. To understand this type of motion, it is important to analyze the forces acting upon an object on an inclined plane. The diagram at the right depicts the two forces acting upon a crate which is positioned on an inclined plane (assumed to be friction-free). As shown in the diagram, there are always at least two forces acting upon any object that is positioned on an inclined plane - the force of gravity and the normal force. The force of gravity (also known as weight) acts in a downward direction; yet the normal force acts in a direction perpendicular to the surface (in fact, *normal* means "perpendicular").

The first peculiarity of inclined plane problems is that the normal force is not directed in the direction which we are accustomed to. Up to this point in the course, we have always seen normal forces acting in an upward direction, opposite the direction of the force of gravity. But this is only because the objects were always on horizontal surfaces (and never upon inclined planes). The truth about normal forces is not that they are always upwards, but rather that they are always directed perpendicular to the surface that the object is on.

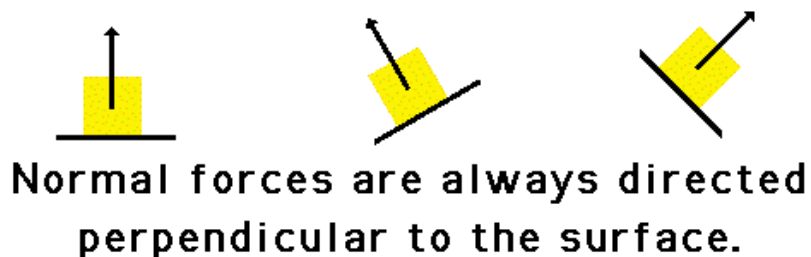

<http://www.glenbrook.k12.il.us/gbssci/phys/Class/BBoard.html>

The task of determining the net force acting upon an object on an inclined plane is a difficult manner since the two (or more) forces are not directed in opposite directions. Thus, one (or more) of the forces will have to be resolved into perpendicular components in order to facilitate their addition to the other forces acting upon the object. Usually, any force directed at an angle to the horizontal is resolved into horizontal and vertical components; however, this is not the process that we will pursue with inclined planes. Instead, the process of analyzing the forces acting upon objects on inclined planes will involve resolving the weight vector (F_{grav}) into two perpendicular components. This is the second peculiarity of inclined plane problems. The force of gravity will be resolved into two components of force - one directed parallel to the inclined surface and the other directed perpendicular to the inclined surface. The diagram below shows how the force of gravity has been replaced by two components - a parallel and a perpendicular component of force.

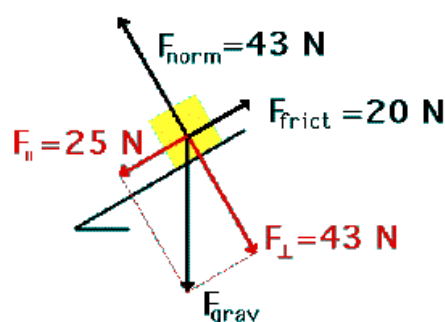

The net force is 5 N.

The perpendicular component of the force of gravity is directed opposite the normal force and as such balances the normal force; the parallel component of the force of gravity is not balanced by any other force. This object will subsequently accelerate down the inclined plane due to the presence of an unbalanced force. It is the parallel component of the force of gravity which causes this acceleration. This principle is summarized in the following graphic

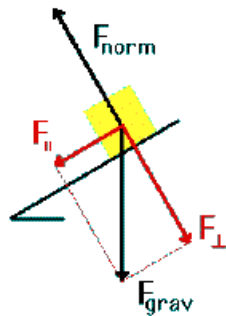

For Objects on Inclines (with no friction)

$$F_{\perp} = F_{\text{norm}}$$

F_{\parallel} is the net force

The task of determining the magnitude of the two components of the force of gravity is a mere matter of using the equations. The equations for the parallel and perpendicular components are:

$$F_{\parallel} = m * g * \sin \theta \quad F_{\perp} = m * g * \cos \theta$$

In the absence of friction and other forces (tension, applied, etc.), the acceleration of an object on an incline is the value of the parallel component ($m * g * \sin \theta$) divided by the mass (m). This yields the equation

$$a = g * \sin \theta$$

(in the absence of gravity)

In the presence of friction or other forces (applied force, tensional forces, etc.), the situation is slightly more complicated. Consider the diagram shown at the right. The perpendicular component of force still balances the normal force (since objects do not accelerate perpendicular to the incline). Yet the frictional force must also be considered when determining the net force. As in all net force problems, the net force is the vector sum of all the forces. That is, all the individual forces are added together as vectors. The parallel component and the normal force add to 0 N; the parallel component and the friction force add together to yield 5 N. The net force is 5 N, directed along the incline towards the floor.

The above problem (and all inclined plane problems) can be simplified through a useful trick known as "tilting the head." An inclined plane problem is in every way like any other net force problem with the sole exception that the surface has been tilted. Thus, to transform the problem back into the form with which you are more comfortable, merely tilt your head in the same direction that the incline was tilted. Or better yet, merely tilt the page of paper (a sure remedy for TNS - "tilted neck syndrome") so that the surface no longer appears level. This is illustrated below.

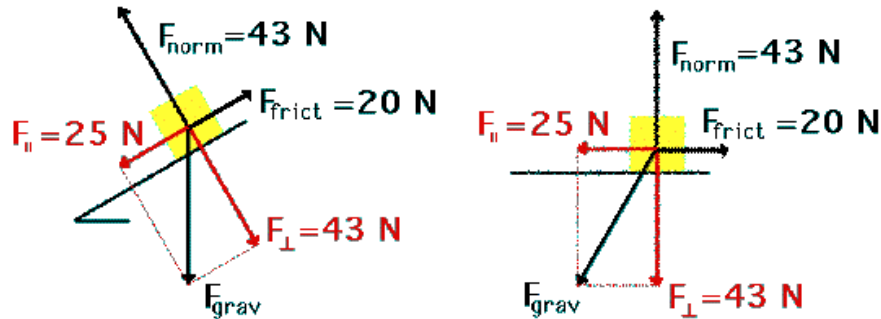

<http://www.glenbrook.k12.il.us/gbssci/phys/Class/BBoard.html>

Once the force of gravity has been resolved into its two components and the inclined plane has been tilted, the problem should look very familiar. Merely ignore the force of gravity (since it has been replaced by its two components) and solve for the net force and acceleration.

As an example consider the situation depicted in the diagram at the right. The free-body diagram shows the forces acting upon a 100-kg crate which is sliding down an inclined plane. The plane is inclined at an angle of 30 degrees. The coefficient of friction between the crate and the incline is 0.3. Determine the net force and acceleration of the crate.

Begin the above problem by finding the force of gravity acting upon the crate and the components of this force parallel and perpendicular to the incline. The force of gravity is 1000 N and the components of this force are $F_{\text{parallel}} = 500 \text{ N}$ ($1000 \text{ N} \cdot \sin 30 \text{ degrees}$) and $F_{\text{perpendicular}} = 866 \text{ N}$ ($1000 \text{ N} \cdot \cos 30 \text{ degrees}$). Now the normal force can be determined to be 866 N (it must balance the perpendicular component of the weight vector). The force of friction can be determined from the value of the normal force and the coefficient of friction; F_{frict} is 260 N ($F_{\text{frict}} = \mu \cdot F_{\text{norm}} = 0.3 \cdot 866 \text{ N}$). The net force is the vector sum of all the forces. The forces directed perpendicular to the incline balance; the forces directed parallel to the incline do not balance. The net force is 240 N ($500 \text{ N} - 260 \text{ N}$). The acceleration is 2.4 m/s^2 ($F_{\text{net}}/m = 240 \text{ N}/100 \text{ kg}$).

Practice The two diagrams below depict the free-body diagram for a 1000-kg roller coaster on the first drop of two different roller coaster rides. Use the above principles of vector resolution to determine the net force and acceleration of the roller coaster cars. Assume a negligible effect of friction and air resistance.

Diagram A

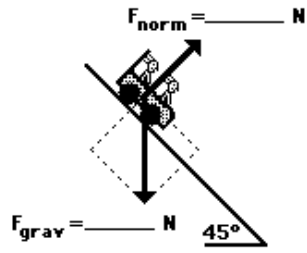

$m = 1000 \text{ kg}$
 $a = \text{_____ m/s/s}$
 $F_{\text{net}} = \text{_____ N}$

Diagram B

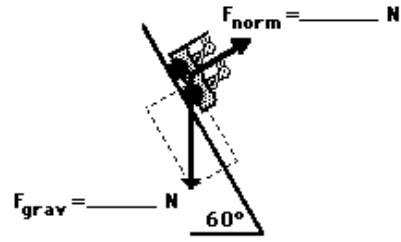

$m = 1000 \text{ kg}$
 $a = \text{_____ m/s/s}$
 $F_{\text{net}} = \text{_____ N}$

<http://www.glenbrook.k12.il.us/gbssci/phys/Class/BBoard.html>

- Chapter 3-

- I. Statics
- II. Motion
 - a. Motion in One-Dimension (1-D) & Two-Dimension (2-D)
 - b. Motion in Three-Dimension (3-D)
- III. Newton's Laws of Motion
 - a. 1st Law & 2nd Law of Motion
 - b. 3rd Law

I. Statics



Ref:

<http://www.glenbrook.k12.il.us/gbssci/phys/Class/BBoard.html>

http://en.wikipedia.org/wiki/Main_Page

<http://www.grc.nasa.gov/WWW/K-12/aerores.htm>

Introduction to Engineering Curriculum PREP I

Problem Solving - Geometry Curriculum PREP I

Photos of:

Texas Department of Transportation IH-10 & Loop 410 Interchange, San Antonio, TX

Equilibrium and Statics

When all the forces which act upon an object are balanced, then the object is said to be in a state of equilibrium. The forces are considered to be balanced if the rightward forces are balanced by the leftward forces and the upward forces are balanced by the downward forces. This however does not necessarily mean that the forces are equal. Consider the two objects pictured in the force diagram shown below. Note that the two objects are at equilibrium because the forces which act upon them are balanced; however, the individual forces are not equal.



These two objects are at equilibrium since the forces are balanced. However, the forces are not equal.

<http://www.glenbrook.k12.il.us/gbssci/phys/Class/BBoard.html>

If an object is at equilibrium, then the forces are balanced. Thus, the net force is zero and the acceleration is 0 m/s/s. Objects at equilibrium must have an acceleration of 0 m/s/s (this extends from Newton's first law of motion), yet that does not mean the object is at rest. An object at equilibrium is either ...

- at rest and staying at rest , or
- in motion and continuing in motion with the same speed and direction.

This too extends from Newton's first law of motion.

If an object is at rest and is in a state of equilibrium, then we would say that it is at "static equilibrium." "Static" means stationary or at rest. In the "Equilibrium Lab," the state of an object was analyzed in terms of the forces acting upon the object. The object was a point on a string upon which three forces were acting. See diagram at right. If the object is at equilibrium, then the net force acting upon the object should be 0 Newtons. Thus, if all the forces are added together as vectors, then the resultant force (the vector sum) should be 0 Newtons. (Recall that the net force is "the vector sum of all the forces" or the resultant of adding all the individual forces head-to-tail.) Thus, we constructed an accurately-drawn, vector addition diagram to determine the resultant. Sample data for this lab are shown below.

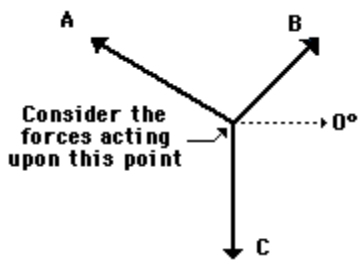

	Force A	Force B	Force C
Magnitude	3.4 N	9.2 N	9.8 N
Direction	161 deg.	70 deg.	270 deg

<http://www.glenbrook.k12.il.us/gbssci/phys/Class/BBoard.html>

For most students, the resultant was 0 Newtons (or at least very close to 0 N). This is what we expected - since the object was at equilibrium, the net force (vector sum of all the forces) should be 0 N.

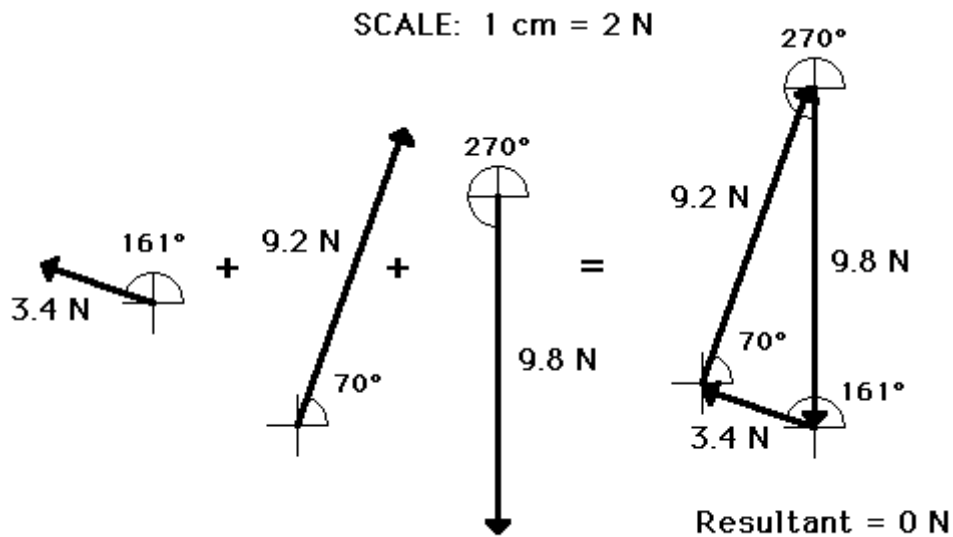

<http://www.glenbrook.k12.il.us/gbssci/phys/Class/BBoard.html>

Another way of determining the net force (vector sum of all the forces) involves using the trigonometric functions to resolve each force into its horizontal and vertical components. Once the components are known, they can be compared to see if the vertical forces are balanced and if the horizontal forces are balanced. The diagram below shows vectors A, B, and C and their respective components. For vectors A and B, the vertical components can be determined using the sine of the angle and the horizontal components can be analyzed using the cosine of the angle. The magnitude and direction of each component for the sample data are shown in the table below the diagram.

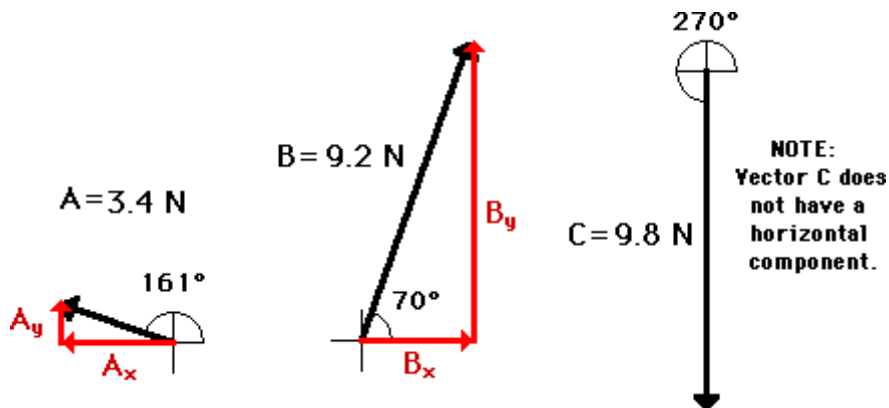

<http://www.glenbrook.k12.il.us/gbssci/phys/Class/BBoard.html>

The data in the table above show that the forces nearly balance. An analysis of the horizontal components shows that the leftward component of A nearly balances the rightward component of B. An analysis of the vertical components show that the sum of the upward components of A + B nearly balance the downward component of C. The vector sum of all the forces is (nearly) equal to 0 Newtons. But what about the 0.1 N difference between rightward and leftward forces and between the upward and downward forces? Why do the components of force only nearly balance? To shed light on this, recall that the sample data used in this analysis are the result of measured data from an actual experimental set-up. The 0.1 N difference is due to the built-in error in the measuring devices which were used to measure force A and force B. This amount of error is small when compared with the fluctuations in the needle on the force scale. We would have to

conclude that this low margin of experimental error reflects an experiment with excellent results. As they say, "Not bad for government work."

II. Motion

Motion in 1 Dimension

We will begin this lesson in mechanics by throwing out some of the complicating issues which clutter the general picture. Then when we have a solid understanding of the basics we can add these discarded factors back into our thinking.

For the time being we will describe the motion we are studying in terms of space and time without explicitly considering the agents that cause the motion. This simplification is so common that a name has been given to this branch of mechanics. It is called **kinematics**. One of the fundamental concepts in kinematics is displacement which is the difference in position of an object at two different times. In this lesson we will combine the displacement idea with the rate of change notion to develop velocity and acceleration. Then we will use the concepts of displacement, velocity and acceleration to study the motion of objects.

There are three types of motion that we will study in mechanics. These are translation, rotation and vibration. Translation is motion along some path from one place to another, like a car moving down a highway. Rotation is motion around some axis, like the Earth's daily motion. Vibration is a back and forth motion like the pendulum of a clock. For the purposes of this lesson we will not consider rotation, limiting ourselves to motion in a straight line. This simplification eliminates the need to use vectors to measure the quantities describing the motion. The straight-line motion is the reason we use 1 Dimension in the title of this lesson. Also by placing this restriction on the motion we will study, we only need to consider objects that are particles, meaning that their size does not enter into our consideration.

Since we are going to be interested in motion in a straight line, we can limit our reference frame to a single real number line and let each number on the line represent a unique position of the particle. Let's call this number line the x axis, so that x stands for particle position. The motion of a particle is completely known if for every time, t, we know its position, x. A convenient way to display the motion of a particle then is to plot its position vs. time on a two dimensional graph as shown in the Motion Plot display.

When it doesn't go faster and faster...

In our previous discussion of one-dimensional motion we used a model in which the acceleration was itself a varying function of time. By introducing yet another simplification, we can get at several interesting examples of motion without getting bogged down in complicated mathematics. Consider the case of acceleration that is constant over time. This case is actually what we see when objects are accelerated by gravity near the surface of a planet such that the distance the object covers in its travels is small compared to the distance to the center of the planet. You know, tossed eggs, thrown rocks, cannon balls... that sort of thing.

With acceleration being a constant, the average value which is given by:

$$\vec{a} = \frac{(v_f - v_i)}{(t_f - t_i)}$$

which is the same as the instantaneous value. The subscript i refers to an initial condition and the subscript f refers to a later condition. The initial velocity v_i is that measured at time t_i and the final velocity v_f is that measured at time t_f .

Motion in 2 Dimensions

In attempting to pin down the location of a particle in a reference frame, we were led into the swamp of vector arithmetic so to speak. Let's try at this point to pick up the thread of our story. We are still dealing with the kinematics of a single particle here but we have relaxed the 1 dimensional restriction applied earlier. For the time being let's restrict ourselves to a two dimensional space since the ideas are the same and the third dimension complicates the pictures. As we did in the 1 dimensional case, we will first work with the general relationships among particle position, velocity and acceleration, then consider the special case of constant acceleration in order to get at some simple equations describing the particle motion.

In our discussion of functions we identified an independent and a dependent variable, then related one to another through a function. This led to a graphical representation of the function. For example we plotted $x=10*t-t^2$. In physics, we are going to want to predict the future so our interest will be in expressing each of the parameters of particle motion as a function of time, making time the independent variable and things like position , velocity and acceleration the dependent variables.

When we introduced the idea of a rate of change of a dependent variable with respect to an independent variable, the initial example was speed being the rate of change of distance with respect to time. So we have already seen one instance of time being the independent variable. Distance and speed are scalar quantities. The vector equivalents are "displacement" and "velocity", including the direction intelligence along with the magnitude. Displacement is defined as a change in position which we remember is the difference between two vectors, an initial position and a final position. I illustrated this in the vector subtraction display. If the vectors \mathbf{r}_1 and \mathbf{r}_2 represent an initial and final position then the vector $\Delta \mathbf{r} = \mathbf{r}_2 - \mathbf{r}_1$ represents a displacement. The use of \mathbf{r} to represent position in more than 1 dimension is common in the literature, possibly derived from radius being the distance from a center to a point.

III. Newton's Laws of Motion

Newton's Laws of Motion & Kinematic Equations

You may have detected a cause and effect relationship among the elements of motion we have been studying under the heading of **kinematics** . Consider a particle at rest in our reference frame. It can't undergo a displacement, which is change position, without getting a velocity. It can't change its velocity from zero without getting acceleration. Acceleration seems to be at the root of motion as far as kinematics is concerned. Now we need to peel back the next layer and look at the cause of acceleration.

That takes us out of the realm of kinematics into the next level of mechanics, called **dynamics** .

A fundamental concept in dynamics is the dynamical system. Since dynamics is the study of **motion and forces** , things that move or things under the influence of forces or both are called dynamical systems. For example a satellite in orbit around the Earth is a dynamical system. So also might a beating heart be considered a dynamical system.

So where did the word "system" come from? What makes an object a system? In general a system is considered to be a thing composed of more than one part. Now I do not want to make too big a deal about this one word "system" because I am not sure all that much thought went into choosing this word back in the early days, but in fact we cannot study the motion of a single isolated point. Think about it. Things only move relative to other things, like an observer for example. So if there is motion there is a system. Likewise no force exists for a single isolated particle so again the word system seems to apply.



http://en.wikipedia.org/wiki/Main_Page

By applying the laws of nature to a dynamical system, we may determine its future behavior. That is really what science is all about. Predicting the future. We are in this business so as to predict the future early enough and accurately enough to profit from our knowledge.

The technique of predicting the future of a dynamical system by application of the laws of nature which govern its change as time passes is called "mathematical modeling". The way it works is this. We discover somehow the laws relating the physical quantities of the dynamical system to time. We express those laws in mathematical terms. The resulting equations may involve the derivative of some of the variables with respect to time. Then we solve the equations using the things we know to calculate the things we don't know.

This is called modeling because the mathematical functions derived from the laws of nature display the behavior of the observable quantities of the actual system. That means that we can avoid the time and expense involved in building an actual model of the dynamical system, assuming that it is even possible to build such a model. We will not, in this course be building mathematical models like that in the diagram on the left. It just illustrates one of the possibilities.

1st Law of Motion

Newton's first law of motion, sometimes called the law of inertia, was actually adopted by Newton from the work of Galileo. It states that a particle's velocity will not change unless a force is applied to the particle. This means that if a "body" (a collection of particles having appreciable mass) is at rest it remains at rest unless a force is applied. If a body is moving with some velocity, it will continue to move with the same velocity unless a force is applied. The first law is really just a qualitative statement about the persistence of motion.

Newton's second law gets into a quantitative relationship between forces and motion. For this we need to revisit the rate of change idea. We defined velocity as the rate of change of position, a small displacement divided by the corresponding change in time, as $\mathbf{v} = \Delta \mathbf{r} / \Delta t$. The velocity vector itself may change over time so it too has a rate of change. That rate of change of velocity is called "acceleration". The acceleration of a body is the change in velocity divided by the corresponding change in time, as $\mathbf{a} = \Delta \mathbf{v} / \Delta t$. We have no single word analogous to displacement, describing the change in velocity.

2nd Law of Motion

The second law states that the acceleration of a body is proportional to the force on it. This is consistent with our experience that the harder we push on a moveable body, the quicker its speed changes. The second law goes on to state that the constant of proportionality between the force and the acceleration is the "mass" of the body. In the form of an equation the second law reads $\mathbf{F} = m \cdot \mathbf{a}$, where \mathbf{F} is the force vector, m is the scalar mass, and \mathbf{a} is the acceleration vector. The mass may be considered the property of a body that determines its resistance to changing its velocity.

We are using the kilogram as the unit of mass, as stated earlier. The unit of length is the meter, so displacement is in meters. Velocity is calculated as displacement divided by time so its units are meters per second. Acceleration is calculated as velocity divided by time so its units are meters per second per second, or meters per second squared. The force sufficient to accelerate one kilogram by one meter per second squared is called one Newton, in honor of the old gentleman himself, seen at the right.

You may have observed that the first law is contained in the second as the special case where force and therefore acceleration are zero.

3rd Law of Motion

Newton's third law addresses the nature of forces. The implicit assumption is that a force is simply a manifestation of the interaction between a pair of bodies. You might say there can not be a pushed without a pusher. The third law states that the force resulting from the interaction of two bodies acts with equal magnitude on both of them and in opposite directions. **For every action, there is an equal and opposite reaction.**

These three laws of nature credited to Newton are not all there are but they are enough to allow us to get started in building and analyzing mathematical models of some dynamical systems.

Circular Motion

Imagine that a particle is subject to a force of constant magnitude but whose direction may change. The particle's acceleration at any instant would be in the direction of the force at that instant. The change in the particle's velocity over a very short time would be a vector in the direction of the average acceleration. The new velocity at the end of this tiny time interval would be the vector sum of the original velocity and the change in velocity. The displacement of the particle during the little time slice would be given by the average velocity times the Δt . Now suppose that the changing direction of the force was such that the force was always perpendicular to the velocity. The Central Force display illustrates this situation.

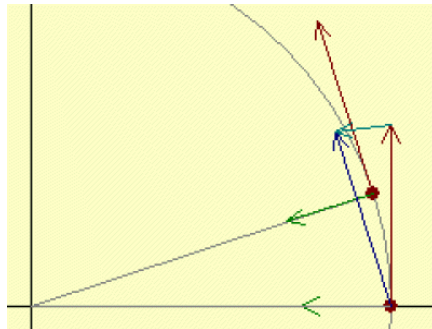

Problem Solving - Geometry Curriculum PREP I

<http://www.glenbrook.k12.il.us/gbssci>

Notice that in this example that the force bends the path of the particle into a circle and that the force vector and therefore the acceleration always points toward the center of that circular path. The magnitude of the velocity along the path remains constant. Under these conditions the particle is said to be undergoing uniform circular motion where "uniform" means the speed of the particle is constant. We have evidently caught this system in a delicate balance where in each Δt the force deflects the particle just enough from the trajectory it would have followed, a straight line in the direction of the velocity, that it ends up on a circular path. The question now is what must be the relationship among the acceleration, velocity and radius of the circle for us to get this nice result.

- Chapter 4 -

I. Kinematics & Dynamics

- a. Distance & Displacement
- b. Speed & Velocity
- c. Average Speed & Velocity
- d. Acceleration.
 1. Constant Acceleration due to gravity
 2. Calculating Acceleration
 3. Direction of the Acceleration Vector
 4. Rates of Change

Ref:

<http://www.glenbrook.k12.il.us/gbssci/phys/Class/BBoard.html>

http://en.wikipedia.org/wiki/Main_Page

<http://www.grc.nasa.gov/WWW/K-12/aerores.htm>

Introduction to Engineering Curriculum PREP I

Problem Solving - Geometry Curriculum PREP I

I. Kinematics & Dynamics

The next set of lessons focus on the physics of motion. As you learn the language, principles, and laws that explain the motion of objects, your efforts should focus on internalizing the meaning of the information. Avoid memorization and avoid abstracting the information from the physical world, which it describes and explains. Rather, contemplate the information, thinking about its meaning and its applications and allow the mathematics speak to you.

Kinematics is the science of describing the motion of objects using words, diagrams, numbers, graphs, and equations. The goal of any study of kinematics is to develop sophisticated mental models, which serve to describe (and ultimately, explain) the motion of real-world objects. This lesson will investigate the words as well as numbers used to describe the motion of objects – that is, the language of kinematics. The equations listed below are often used to describe the motion of objects using numbers. Your goal is to become very familiar with their meanings and applications.

Newton's Four Kinematic Equations of Motion

$$d = v_i t + at^2$$

$$v_f = v_i + at$$

$$v_f^2 = v_i^2 + 2ad$$

$$d = \frac{v_i + v_f}{2} t$$

d : distance

v_i : initial _ velocity

v_f : final _ velocity

a : gravitatio nal _ accelerati on

t : time

By algebraically rearranging these equations, you will be able to solve for other variables such as acceleration or initial velocity v_i .

Distance and Displacement

Distance and displacement are two quantities which may seem to mean the same thing, yet they have distinctly different meanings and definitions.

- **Distance** is a scalar quantity, which refers to "how much ground an object has covered" during its motion.
- **Displacement** is a vector quantity, which refers to "how far out of place an object is"; it is the object's change in position.

Speed & Velocity

Just as distance and displacement have distinctly different meanings (despite their similarities), so do speed and velocity.

Speed is a scalar quantity, which refers to "how fast an object is moving." A fast-moving object has a high speed while a slow-moving object has a low speed. An object with no movement at all has a zero speed.

Velocity is a vector quantity, which refers to "the rate at which an object changes its position." Imagine a person moving rapidly - one step forward and one step back - always returning to the original starting position. While this might result in a frenzy of activity, it would also result in a zero velocity. Because the person always returns to the original position, the motion would never result in a change in position. Since velocity is defined as the rate at which the position changes, this motion results in zero velocity. If a person in motion wishes to maximize his/her velocity, then that person must make every effort to maximize the amount that he/she is displaced from his/her original position. Every step must go into moving that person further from where he/she started. For certain, the person should never change directions and begin to return to where he/she started.

Describing Speed & Velocity:

Velocity is a vector quantity. As such, velocity is "direction-aware." When evaluating the velocity of an object, you must keep track of its direction. It would not be enough to say that an object has a velocity of 55 mi/hr. You must include direction information in order to fully describe the velocity of the object. For instance, you must describe an object's velocity as being 55 mi/hr, east. This is one of the essential differences between speed and velocity. Speed is a scalar and does not keep track of direction; velocity is a vector and is direction-aware.

The task of describing the direction of the velocity vector is easy! The direction of the velocity vector is the same as the direction in which an object is moving. It does not matter whether the object is speeding up or slowing down, if the object is moving rightwards, then its velocity is described as being rightwards. If an object is moving downwards, then its velocity is described as being downwards. Thus an airplane moving towards the west with a speed of 300 mi/hr has a velocity of 300 mi/hr, west. Note that speed has no direction (it is a scalar) and that velocity is simply the speed with a direction.

Average Speed and Average Velocity

As an object moves, it often undergoes changes in speed. For example, during an average trip to school, there are many changes in speed. Rather than the speedometer maintaining a steady reading, the needle constantly moves up and down to reflect the stopping and starting and the accelerating and decelerating. At one instant, the car may be moving at 50 mi/hr and at another instant, it may be stopped (i.e., 0 mi/hr). Yet during the course of the trip to school the person might average a speed of 25 mi/hr.

The average speed during the course of a motion is often computed using the following equation:

$$\text{Average Speed} = \frac{\text{Distance Traveled}}{\text{Time of Travel}}$$

Meanwhile, the average velocity is often computed using the equation:

$$\text{Average Velocity} = \frac{\Delta \text{position}}{\text{time}} = \frac{\text{displacement}}{\text{time}}$$

Acceleration

The final mathematical quantity discussed in Lesson 1 is acceleration. An often misunderstood quantity, acceleration has a meaning much different from the meaning sports announcers and other individuals associate with it. In the form of a definition, **Acceleration** is a vector quantity, which is defined as "the rate at which an object changes its velocity." An object is accelerating if it is changing its velocity

Constant Acceleration

Sometimes an accelerating object will change its velocity by the same amount each second. As mentioned before, the data above shows an object changing its velocity by 10 m/s in each consecutive second. This is known as a constant acceleration since the velocity is changing by the same amount each second. An object with a constant acceleration should not be confused with an object with a constant velocity. Don't be fooled! If an object is changing its velocity – whether by a constant amount or a varying amount – it is an accelerating object. An object with a constant velocity is not accelerating. The data tables below depict motions of objects with a constant acceleration and with a changing acceleration. Note that each object has a changing velocity.

Since accelerating objects are constantly changing their velocity, you can say that the distance traveled divided by the time taken to travel that distance is not a constant value. A falling object for instance usually accelerates as it falls. If you were to observe the motion of a free-falling object (free fall motion will be discussed in detail later), you would notice that the object averages a velocity of 5 m/s in the first second, 15 m/s in the second second, 25 m/s in the third second, 35 m/s in the fourth second, etc. Our free-falling object would be accelerating at a constant rate.

For objects with a constant acceleration, the distance of travel is directly proportional to the square of the time of travel.

Calculating Acceleration:

The acceleration of any object is calculated using the equation:

$$\text{Ave. acceleration} = \frac{\Delta \text{velocity}}{\text{time}} = \frac{v_f - v_i}{t}$$

This equation can be used to calculate the acceleration of the object whose motion is depicted by the velocity-time data table above. The velocity-time data in the table shows that the object has an acceleration of 10 m/s/s. The calculation is shown below:

$$a_{avg} = \frac{v_f - v_i}{t}$$

Initially, these units are a little awkward to the newcomer to physics. Yet, they are very reasonable units when you consider the definition of and equation for acceleration. The reason for the units becomes obvious upon examination of the acceleration equation.

$$a = \frac{\Delta \text{velocity}}{\text{time}}$$

Since acceleration is a velocity change over a time interval, the units for acceleration are velocity units divided by time units – thus (m/s)/s or (mi/hr)/s.

Direction of the Acceleration Vector

Acceleration is a **vector quantity** so it will always have a direction associated with it. The direction of the acceleration vector depends on two factors:

- whether the object is speeding up or slowing down
- whether the object is moving in the positive (+) or negative (–) direction

The general **RULE OF THUMB** is:

If an object is slowing down, then its acceleration is in the opposite direction of its motion.

This **RULE OF THUMB** can be applied to determine whether the sign of the acceleration of an object is positive or negative, right or left, up or down, etc. Consider the two data tables below.

Acceleration values are expressed in units of velocity per time. Typical acceleration units include the following:

m/s/s
mi/hr/s
km/hr/s

Rates of Change

The next concept we need to put in our toolbox is the notion of "rate of change". The example that most of us were first exposed to was speed being the rate of change of distance. My first science course, and probably yours as well, contained the formula,

$$velocity = \frac{distance}{time}$$

This is the prototype of all rate of change formulae. In general a rate of change may be the change in anything divided by the corresponding change in a related variable. The "slope" of a graph of y vs. x for example is the change in y divided by the corresponding change in x. It is called the rate of change in y with respect to x. Since we are going to be studying dynamical systems where time is normally taken to be the independent variable, we will make that the case in our examples.

Since t is the independent variable, we will pick two points on the t-axis to be the interval over which we will calculate the rate of change. The difference between these t values is called "delta t". The upper case Greek letter delta (Δ) is used as a symbol of this finite difference. Customarily we subtract the lower t value from the higher to get Δt .

For each of the chosen t values there will be a corresponding value of x. We get Δx by subtracting the x corresponding with the lower t value from that corresponding to the upper t value. The ratio Δx over Δt is the rate of change, and for a straight line, the slope of that line. Run the Linear Rate of Change display to experiment with this. I have chosen a Δt of 0.5 units for this display. You may select the lower value of t using the cursor. The x cursor value will be ignored. As you will see, the slope of a linear function is a constant.

- Chapter 5-

- I. Work & Energy
 - a. Conservation of Energy
 - b. Transfer of Energy
- II. Potential Energy
- III. Kinetic Energy
 - a. Mechanical Energy

Ref:

<http://www.glenbrook.k12.il.us/gbssci/phys/Class/BBoard.html>

http://en.wikipedia.org/wiki/Main_Page

<http://www.grc.nasa.gov/WWW/K-12/aerores.htm>

Introduction to Engineering Curriculum PREP I

I. Work & Energy

In physics, work is defined as a force acting upon an object to cause a displacement. There are three key words in this definition - force, displacement, and cause. In order for a force to qualify as having done work on an object, there must be a displacement and the force must cause the displacement. There are several good examples of work which can be observed in everyday life - a horse pulling a plow through the fields, a father pushing a grocery cart down the aisle of a grocery store, a freshman lifting a backpack full of books upon her shoulder, a weightlifter lifting a barbell above her head, a shot-put launching the shot, etc. In each case described here there is a force exerted upon an object to cause that object to be displaced.

Consider a free particle of *mass*, m , at rest in our reference frame. Next suppose that we apply a force in the x direction to the particle and that the magnitude of that force is a function of x , $f=f(x)$. Since our particle was at rest before we applied this force to it, all the other forces on the particle, if any, balance each other out and the applied force is the net or "resultant" force. Now let's consider a tiny *time interval* dt (change in time or a.k.a Δ time) short enough so that the force is nearly constant during the interval. The *average acceleration* of the particle over the interval dt is:

$$a = \frac{(v - v_o)}{\Delta t}$$

where v_o is the initial velocity and v is the final velocity.

The *distance x traveled* by the particle during time interval dt is the average velocity times the time interval:

$$x = \frac{(v + v_o)}{2} \Delta t$$

The work, w , done on the particle is the force f times the distance x . The force f though, from Newton's second law is $F = m \times a$, so the work is:

$$Work = Mass \times Acceleration \times Distnace$$

or

$$\begin{array}{c} \overrightarrow{d} \\ \overrightarrow{F} \end{array} \quad \Theta = 0 \text{ degrees}$$

$$\begin{array}{c} \overrightarrow{d} \\ \overleftarrow{F} \end{array} \quad \Theta = 180 \text{ degrees}$$

$$\overrightarrow{d} \quad \uparrow F \quad \Theta = 90 \text{ degrees}$$

<http://www.glenbrook.k12.il.us/gbssci/phys/Class/BBoard.html>

$$Work = \frac{m(v - v_o)}{\Delta t} \times \frac{(v + v_o)}{2} \Delta t$$

Simplifying the preceding mess,

$$Work = \frac{mv^2}{2} - \frac{mv_o^2}{2}$$

Mathematically, work can be expressed by the following equation.

$$W = F * d * \cos \Theta$$

where

F = force,

d = displacement, and

the angle (theta) is defined as the angle between the force and the displacement vector.

Perhaps the most difficult aspect of the above equation is the angle "theta." The angle is not just any 'ole angle, but rather a very specific angle. The angle measure is defined as the angle between the force and the displacement. To gather an idea of its meaning, consider the following three scenarios.

- Scenario A: A force acts rightward upon an object as it is displaced rightward. In such an instance, the force vector and the displacement vector are in the same direction. Thus, the angle between F and d is 0 degrees.
- Scenario B: A force acts leftward upon an object which is displaced rightward. In such an instance, the force vector and the displacement vector are in the opposite direction. Thus, the angle between F and d is 180 degrees.
- Scenario C: A force acts upward upon an object as it is displaced rightward. In such an instance, the force vector and the displacement vector are at right angles to each other. Thus, the angle between F and d is 90 degrees.

determining the measure of the angle in the work equation, it is important to recognize that the angle has a precise definition - it is the angle between the force and the displacement vector. Be sure to avoid mindlessly using any 'ole angle in the equation. For instance, consider the activity performed in the "It's All Uphill" lab. A force was applied to a cart to pull it up an incline at constant speed. Several incline angles were used; yet, the force was always applied parallel to the incline. The displacement of the cart was also parallel to the incline. Since F and d were in the same direction, the angle was 0 degrees. Nonetheless, most students experienced the strong temptation to measure the angle of incline and use it in the equation. Don't forget: the angle in the equation is not just any 'ole angle; it is defined as the angle between the force and the displacement vector.

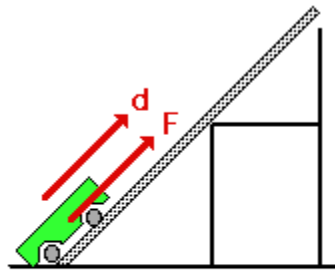

**Whenever F and d are
in the same direction,
 $\theta = 0$ degrees.**

<http://www.glenbrook.k12.il.us/gbssci/phys/Class/BBoard.html>

Whenever a new quantity is introduced in physics, the standard metric units associated with that quantity are discussed. In the case of work (and also energy), the standard metric unit is the Joule (abbreviated "J"). One Joule is equivalent to one Newton of force causing a displacement of one meter. In other words,

**The Joule is the unit of work.
1 Joule = 1 Newton * 1 meter
1J = 1 N * m**

II. Potential Energy

Example 1)

Apply the work equation to determine the amount of work done by the applied force in each of the three situations described below.

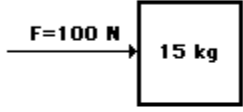
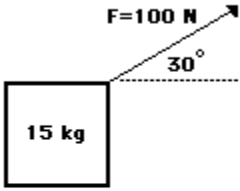
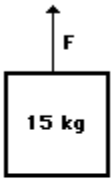
Diagram A	Diagram B	Diagram C
		
A 100 N force is applied to move a 15 kg object a horizontal distance of 5 meters at constant speed.	A 100 N force is applied at an angle of 30° to the horizontal to move a 15 kg object at a constant speed for a horizontal distance of 5 m.	An upward force is applied to lift a 15 kg object to a height of 5 meters at constant speed.

Example 2)

A force of 50 N acts on the block at the angle shown in the diagram. The block moves a horizontal distance of 3.0 m.

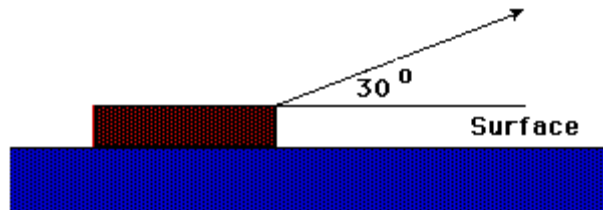

III. KINETIC & POTENTIAL ENERGY

Conservation of Energy

Introduction to Engineering Curriculum PREP I

When the space shuttle is at the launch pad, it appears that it is at rest. As the rockets ignite and the shuttle lifts-off vertically, work is being done on the shuttle to defy gravity. We can refer to this energy of *motion* as **kinetic energy**, and also refer to the *motionless* state as **potential energy**. It is safe to say that any object in motion has a non-zero value of kinetic energy and any motionless object has a non-zero value of potential energy, or has the "potential" of moving. These quantities (values) are scalars; therefore it does not depend on the particle's direction. KE and PE values swap as an object goes from rest to motion or vice-versus, so we can say that energy is conserved. Let's take a look at some illustrations to better understand the physical application of these two terms

$$KE = \frac{1}{2}mv^2 \qquad PE = mgh$$

Units: Joules

m = mass

g = gravity constant 9.81 m/s² or 32.2 ft/s²

h = height

v = velocity

- When the shuttle is on the ground preparing for launch it has no vertical velocity, therefore it has no KE, but would have PE. (it has the "potential" of moving)
- If a person was standing atop of the shuttle, which stands 300 feet above the ground, the person would also have no KE, but plenty of PE.
- The shuttle now launches and is on its way to orbit. KE now exists because velocity now has a non-zero value. PE still exists because a non-zero value exists for all PE variables.

Kinetic & Potential Energy cont:

Let's take a look at this scale of Free Fall:

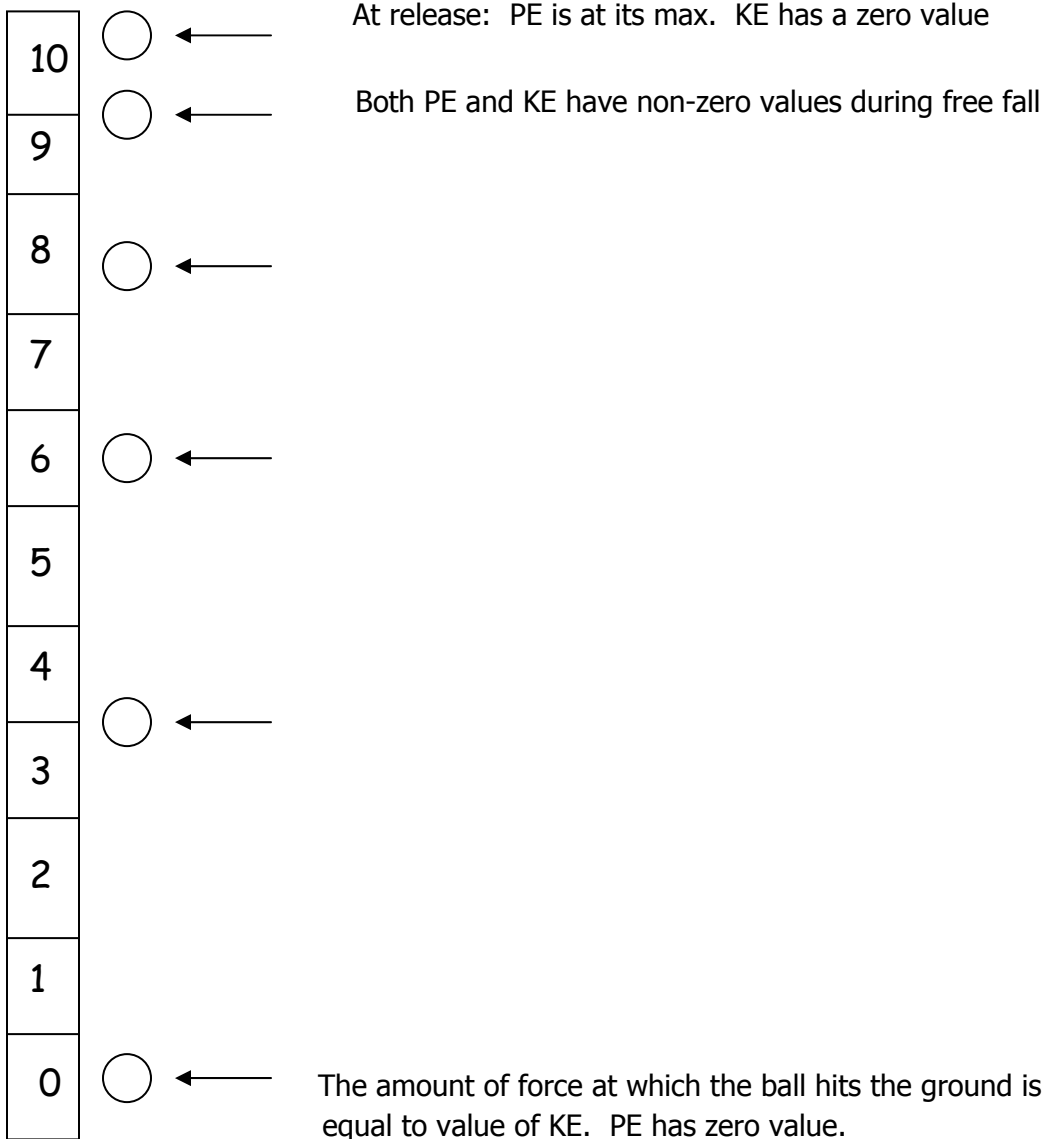

Since the gravitational potential energy of an object is directly proportional to its height above the zero position, a doubling of the height will result in a doubling of the gravitational potential energy. A tripling of the height will result in a tripling of the gravitational potential energy. Use this principle to determine the blanks in the following diagram. Knowing that the potential energy at the top of the tall pillar is 30 J, what is the potential energy at the other positions shown on the hill and the stairs.

Diagram A



Diagram B

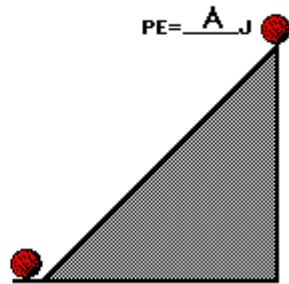
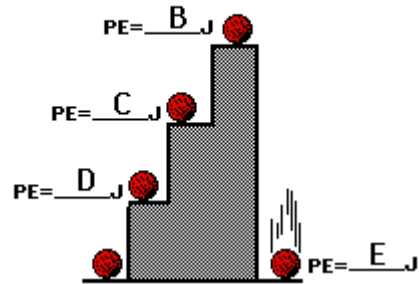

Diagram C



<http://www.glenbrook.k12.il.us/gbssci/phys/Class/BBoard.html>

The second form of potential energy which we will discuss in this course is elastic potential energy. Elastic potential energy is the energy stored in elastic materials as the result of their stretching or compressing. Elastic potential energy can be stored in rubber bands, bungee chords, trampolines, springs, an arrow drawn into a bow, etc. The amount of elastic potential energy stored in such a device is related to the amount of stretch of the device - the more stretch, the more stored energy.

Springs are a special instance of a device which can store elastic potential energy due to either compression or stretching. A force is required to compress a spring; the more compression there is, the more force which is required to compress it further. For certain springs, the amount of force is directly proportional to the amount of stretch or compression (x); the constant of proportionality is known as the spring constant (k).

$$F_{\text{spring}} = k * x$$

Such springs are said to follow Hooke's Law. If a spring is not stretched or compressed, then there is no elastic potential energy stored in it. The spring is said to be at its equilibrium position. The equilibrium position is the position that the spring naturally assumes when there is no force applied to it. In terms of potential energy, the equilibrium position could be called the zero-potential energy position. There is a special equation for springs which relates the amount of elastic potential energy to the amount of stretch (or compression) and the spring constant. The equation is

$$PE_{\text{spring}} = \frac{1}{2} * k * x^2$$

where k = spring constant
 x = amount of compression
 (relative to equilibrium pos'n)

<http://www.glenbrook.k12.il.us/gbssci/phys/Class/BBoard.html>

To summarize, potential energy is the energy which an object has stored due to its position relative to some zero position. An object possesses gravitational potential energy if it is positioned at a height above (or below) the zero height

position. An object possesses elastic potential energy if it is at a position on an elastic medium other than the equilibrium position.

Back to Kinetic Energy

$$KE = \frac{1}{2} * m * v^2$$

where m = mass of object

v = speed of object

Kinetic energy is a scalar quantity; it does not have a direction. Unlike velocity, acceleration, force, and momentum, the kinetic energy of an object is completely described by magnitude alone. Like work and potential energy, the standard metric units of measurement for kinetic energy is the Joule. As might be implied by the above equation, 1 Joule is equivalent to $1 \text{ kg} * (\text{m/s})^2$.

$$1 \text{ Joule} = 1 \text{ kg} * \frac{\text{m}^2}{\text{s}^2}$$

Mechanical Energy

[Mechanical energy is the energy which is possessed by an object due to its motion or its stored energy of position. Mechanical energy can be either kinetic energy (energy of motion) or potential energy (stored energy of position). Objects have mechanical energy if they are in motion and/or if they are at some position relative to a zero potential energy position (for example, a brick held at a vertical position above the ground or zero height position). A moving car possesses mechanical energy due to its motion (kinetic energy). A moving baseball possesses mechanical energy due to both its high speed (kinetic energy) and its vertical position above the ground (gravitational potential energy). A World Civilization book at rest on the top shelf of a locker possesses mechanical energy due to its vertical position above the ground (gravitational potential energy). A barbell lifted high above a weightlifter's head possesses mechanical energy due to its vertical position above the ground (gravitational potential energy). A drawn bow possesses mechanical energy due to its stretched position (elastic potential energy).]

[An object which possesses mechanical energy is able to do work. In fact, mechanical energy is often defined as the ability to do work. Any object which possesses mechanical energy - whether it be in the form of potential energy or kinetic energy - is able to do work. That is, its mechanical energy enables that object to apply a force to another object in order to cause it to be displaced.]

Ref:
<http://www.glenbrook.k12.il.us/gbssci/phys/Class/BBoard.html>

- Chapter 6 -

- I. Fluid Mechanics
 - a. Fluid Flow and its properties
 - b. The Continuity Equation
 - c. Bernoulli's Equation
- II. Fluid Statics

Ref:

<http://www.glenbrook.k12.il.us/gbssci/phys/Class/BBoard.html>

http://en.wikipedia.org/wiki/Main_Page

<http://www.grc.nasa.gov/WWW/K-12/aerores.htm>

Introduction to Engineering Curriculum PREP I

<http://www.aerospaceweb.org/question/aerodynamics/q0094b.shtml>

<http://www.aerospaceweb.org/design/aerospike/figures/fig01.gif>

http://www.the-rocketman.com/archive_photos/funny_nozzle.jpg

Photo of: Texas Department of Transportation

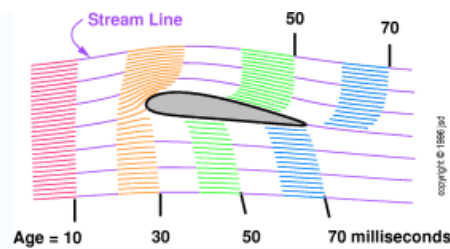

I. Fluid Mechanics

Fluid mechanics or **fluid dynamics** is the study of the macroscopic physical behaviour of fluids . Fluids are specifically liquids and gases though some other materials and systems can be described in a similar way. The solution of a fluid dynamic problem typically involves calculating for various properties of the fluid, such as velocity, pressure, density, and temperature, as functions of space and time. The discipline has a number of subdisciplines, including aerodynamics (the study of gases) and hydrodynamics (the study of liquids). Fluid mechanics has a wide range of applications. For example, it is used in calculating forces and moments on aircraft, the mass flow of petroleum through pipelines, and in prediction of weather patterns, and even in traffic engineering, where traffic is treated as a continuous flowing fluid. Fluid mechanics offers a mathematical structure that underlies these practical disciplines which often also embrace empirical and semi-empirical laws, derived from flow measurement, to solve practical problems.

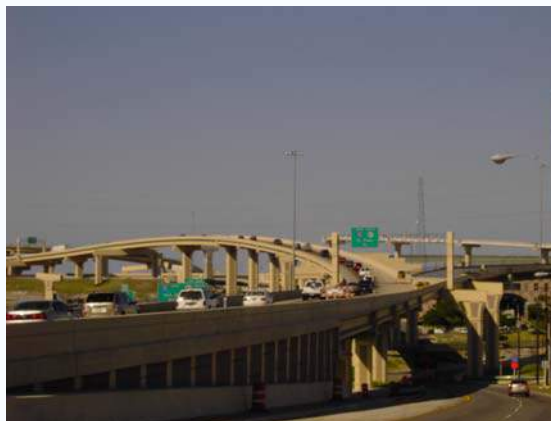

Photo of: Texas Department of Transportation

Aerodynamics is a branch of fluid dynamics concerned with the study of gas flows, first analysed by George Cayley in the 1800's. The solution of an aerodynamic problem normally involves calculating for various properties of the flow, such as velocity, pressure, density, and temperature, as a function of space and time. Understanding the flow pattern makes it possible to calculate or approximate the forces and moments acting on bodies in the flow. This mathematical analysis and empirical approximation form the scientific basis for heavier-than-air flight.



http://en.wikipedia.org/wiki/Main_Page

Compressible Flow: US Navy/Marines F-18 Hornet Supersonic Flight

Aerodynamic problems can be classified in a number of ways. The flow environment defines the first classification criterion. *External* aerodynamics is the study of flow around solid objects of various shapes. Evaluating the lift and drag on an airplane, the shock waves that form in front of the nose of a rocket or the flow of air over a hard drive head are examples of external aerodynamics. *Internal* aerodynamics is the study of flow through passages in solid objects. For instance, internal aerodynamics encompasses the study of the airflow through a jet engine or through an air conditioning pipe.

The ratio of the problem's characteristic flow speed to the speed of sound comprises a second classification of aerodynamic problems. A problem is called subsonic if all the speeds in the problem are less than the speed of sound, transonic if speeds both below and above the speed of sound are present (normally when the characteristic speed is approximately the speed of sound), supersonic when the characteristic flow speed is greater than the speed of sound, and hypersonic. when the flow speed is much greater than the speed of sound. Aerodynamicists disagree over the precise definition of hypersonic flow; minimum Mach numbers for hypersonic flow range from 3 to 12. Most aerodynamicists use numbers between 5 and 8.

Air above the wing is traveling a longer path requiring the air to flow faster, while the air below the wing is traveling a nearly straight and shorter path resulting in slower moving air. Recall, air pressure is directly related to its velocity. Lift is created by the way airplane wings are designed so that the pressure of the air over the wings is less than the pressure

under them. The difference in pressure—less above the wing and greater below—causes the wing to lift. A motor-driven propeller or jet engine that thrusts the plane forward, forcing air to flow over the wings, producing lift.

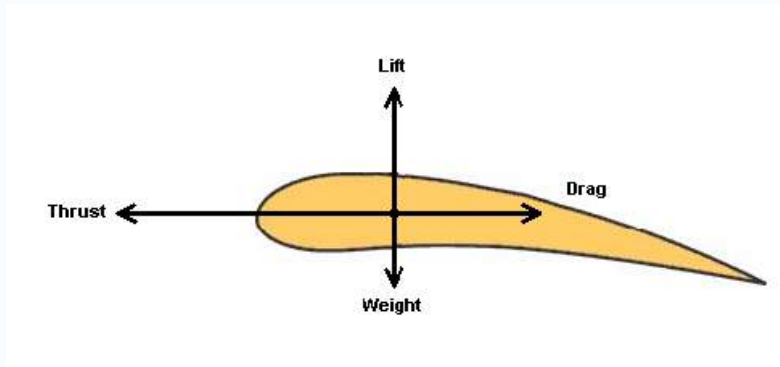

<http://www.glenbrook.k12.il.us/gbssci/phys/Class/BBoard.html>

The influence of viscosity in the flow dictates a third classification. Some problems involve only negligible viscous effects on the solution, in which case viscosity can be considered to be nonexistent. The approximations to these problems are called inviscid flows. Flows for which viscosity cannot be neglected are called viscous flows.

Continuity & Momentum Equation:

$$A_1 v_1 = A_2 v_2$$

Where: A : Area

V: Velocity

$$\sum_{n=1}^n \rho v A = 0$$

Assuming

- Incompressibility (subsonic flow)
- Laminar Flow
- Steady State
- Zero Body Forces

Bernoulli's Law

Glenn
Research
Center

Bernoulli's Equation

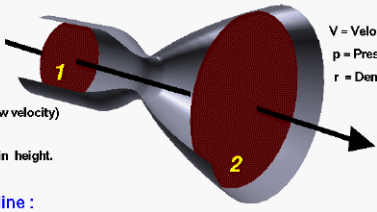

Restrictions :
 Inviscid
 Steady
 Incompressible (low velocity)
 No heat addition.
 Negligible change in height.

Along a streamline :
 static pressure + dynamic pressure = total pressure

$$p_s + \frac{\rho V^2}{2} = p_t$$

$$\left(p_s + \frac{\rho V^2}{2} \right)_1 = \left(p_s + \frac{\rho V^2}{2} \right)_2$$

V = Velocity
 p = Pressure
 ρ = Density

Another way of defining Bernoulli's equation is:

$$\left(\frac{P_1}{\rho} + \frac{V_1^2}{2} + gz_1 \right) = \left(\frac{P_2}{\rho} + \frac{V_2^2}{2} + gz_2 \right)$$

Where:

- P : Pressure
- ρ : density of fluid (air)
- V : Velocity
- g : gravitational acceleration
- z : height of fluid and object

Reynolds's Number:

$$R_e = \frac{DV\rho}{\mu}$$

Where:

- D : Diameter of object
- V : Velocity of air
- ρ : Density of Fluid (air)
- μ : viscosity of fluid (air)

Viscosity is the "stickiness" or friction of the air upon the surface of the object.

What is it about this particular Reynolds number that causes such a large reduction in drag? It turns out that it is at this critical point that the air flowing around the sphere makes an important change. We have already discussed the concept of flow separation. One of the key factors affecting flow separation is the behavior of the boundary layer. The boundary layer is a thin layer of air that lies very close to the surface of a body in motion. It is within this layer that the adverse pressure gradient develops that causes the airflow to separate from the surface.

At low Reynolds numbers, the boundary layer remains very smooth and is called laminar. Laminar boundary layers are normally very desirable because they reduce drag on most shapes. Unfortunately, laminar boundary layers are also very

fragile and separate from the surface of a body very easily when they encounter an adverse pressure gradient. This separated flow is what causes the drag to remain so high below the critical Reynolds number.

At that Reynolds number, however, the boundary layer switches from being laminar to turbulent. The location at which this change in the boundary layer occurs is called the transition point. A turbulent boundary layer causes mixing of the air near the surface that normally results in higher drag. However, the advantage of turbulence is that it speeds up the airflow and gives it more forward momentum. As a result, the boundary layer resists the adverse pressure gradient much longer before it separates from the surface.

Question:

Will a 1/18th flying scale model of a plane have the same Reynolds's Number and flight characteristics as the actual design size?

Why do golf balls have dimples?

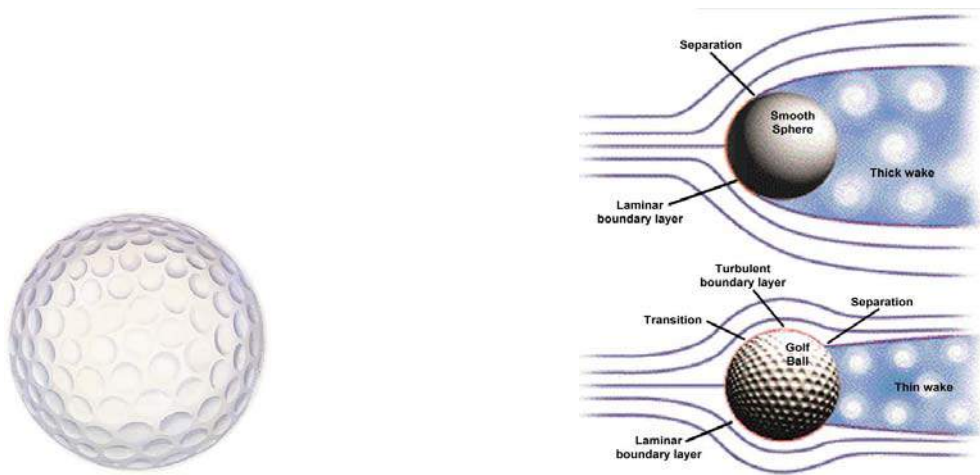

Flow separation on a sphere with a laminar versus turbulent boundary layer

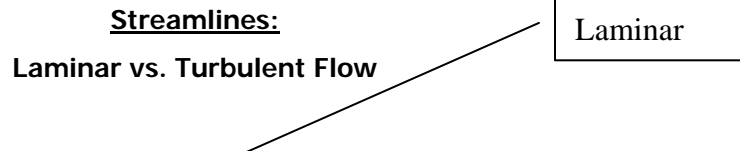

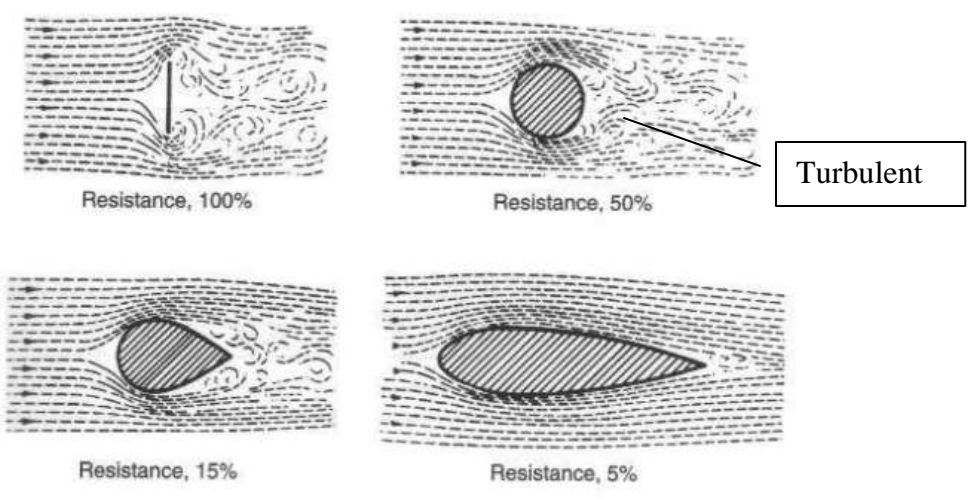

Ref: <http://www.aerospaceweb.org/question/aerodynamics/q0094b.shtml>

BOYLE'S LAW

Topics:

1. Introduce the concept of the Pressure - Volume Relationship
2. Introduce the concept of the Pressure - Temperature - Volume Relationship

Experiments with bottle rockets will be used to explore how actual rockets work. A rocket propels as a result of Newton's 3rd law, which states, "for every action there exist an equal and opposite reaction" (lesson 2). The force exerted on the rocket is directly proportional to the amount of mass expelled per unit of time (*mass flow rate*).

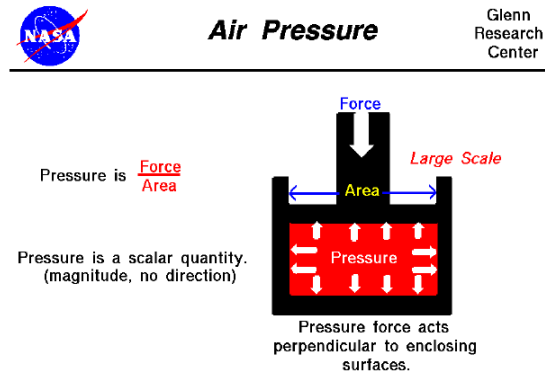

Ref: <<http://wright.nasa.gov>.

Let's revert to the previous lesson of propulsion concerning nozzles. The bottle rockets will be launched upside-down, with the spout as the nozzle. By observation, it is obvious the bottle has a large volume in the center and it decreases as it approached the spout. This is why the spout will act as a *Convergent-Divergent* nozzle. Here is a diagram of how the mass flow rate, volume, & pressure relate in the bottle rocket:

Ref: <http://www.aerospaceweb.org/design/aerospike/figures/fig01.gif>

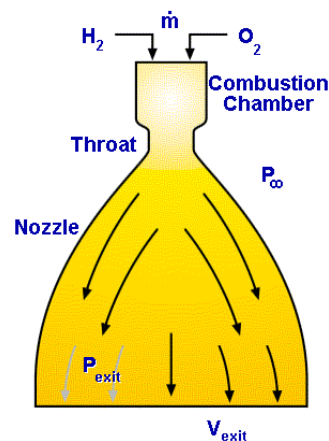

Nozzle Region Characteristics:

Combustion Chamber: Lower Velocity; Higher Pressure

Throat: Higher Velocity; Lower Pressure

Nozzle: Velocity Decreases; Pressure Increases, but Increase in Thrust per unit Area is needed.

Common Units: Pressure : psi = pounds per square inch or Pa = Pascal

Velocity: ft/sec = feet per second or m/s = meters per second

Volume: ft³ = cubic feet, in³ = cubic inches, or m³ = cubic meters

In the mid 1600's, Robert Boyle studied the relationship between the pressure and volume of a confined gas held at a constant temperature. Boyle observed that the product (multiplication) of the pressure and volume are observed to be nearly constant (almost don't change). The product of pressure and volume is exactly a constant for an **ideal gas**. This relationship between pressure and volume is referred to as **Boyle's Law**:

$$P_1 V_1 = P_2 V_2$$

{P: Pressure, V: Volume}

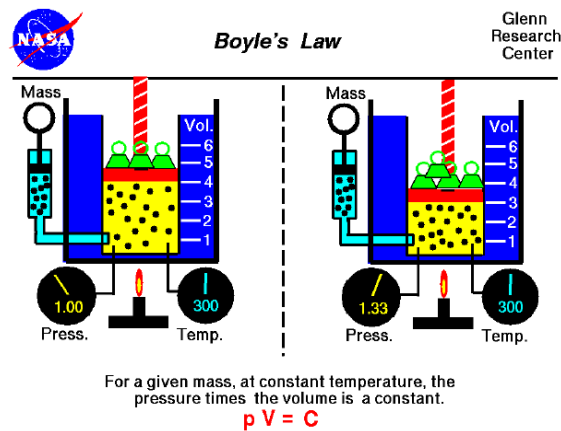

Ref: http://www.the-rocketman.com/archive_photos/funny_nozzle.jpg

Ref: <http://wright.nasa.gov>.

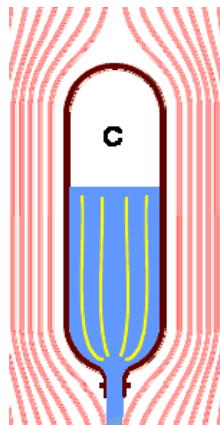

Example: Let's say a very large bottle rocket has an internal pressure of $P_1 = 26$ psi and the internal volume is $V_1 = 7$ in³. What is the exiting pressure, P_2 , if the volume of the spout is $V_2 = 2$ in³ ?

Known:

$P_1 = 26$ psi, $V_1 = 7$ cubic inches, & $V_2 = 2$ in³

Unknown: P_2 , so solve for it!

$$(26 \text{ psi}) (7 \text{ in}^3) = P_2 (2 \text{ in}^3)$$

Isolate P_2 :

$$[(26 \text{ psi})(7 \text{ in}^3)] / (2 \text{ in}^3) = P_2$$

Solve for P1:

$$P1 = 91 \text{ psi}$$

Substitute back into equation to check validity:

$$(26 \text{ psi}) (7 \text{ in}^3) = (91 \text{ psi}) (2 \text{ in}^3)$$
$$182 = 182$$

Get familiar with the rocket's operation so that you understand how pressure, mass, and volume relate. First, you will make neat and accurate drawings of your two rocket designs. Second, you will make predictions of which rocket will go farthest, the Air/Water rocket or the Air rocket. Third, you will construct the rocket according to your drawings and if changes are made you must indicate those alterations in your report. We will then launch the rockets outside using pumps and you will record their horizontal distance traveled and the time of flight to calculate each launch height.

- Chapter 7 -

- I. Electricity
 - a. Electrical Potential
 - b. Ohm's Law
 - c. Parallel & Series Circuits
 - d. Voltage, Current, & Resistance.
 - e. Power
 - f. Transformers (City Public Service of San Antonio)
- II. Optics
 - a. Refractions
 - b. Optical Density & Speed of Light
 - c. Refraction Angle
 - d. Snell's Law
 - e. Anatomy of a Lens

Ref:
<http://www.glenbrook.k12.il.us/gbssci/phys/Class/BBoard.html>
http://en.wikipedia.org/wiki/Main_Page
 Introduction to Engineering Curriculum PREP I
 Photo of:
 City Public Service of San Antonio

Where would the world be without the use of electricity? Electrical use is taken for granted by all those who live on this planet, so let us find out how it works. To begin, the most basic of "laws" is *Ohm's Law*, which will be illustrated along with the fundamental electrical units. Here is a list of terms used in the electrical world:

<u>NAME</u>	<u>EQUATION</u>	<u>UNITS (meaning) - SYMBOL</u>
Voltage		V - Volts (potential)
Resistance		R - Ohms Ω
Current		I - Amps Time Rate of Electrical Flow
Power	$P = I V$	P - Watts or Wattage Relationship between power, current, & voltage
Ohm's Law	$V = I R$	Relationship between voltage, resistance, & current
Direct Current		DC

Alternating Current

AC

SAFETY NOTE & DISCLAIMER: Home wiring is usually 110 VAC or possibly 208 VAC, either way it is extremely dangerous and can kill you. DO NOT perform any electrical experiment using home wiring, for this is our disclaimer if anything should happen to you. In the classroom and lab, we will use low voltage batteries only, which are safe.

Here's a "trick to the trade" to help you with the algebra when using the POWER and OHM'S LAW equation:

1. Cover the variable you want to solve for with your thumb.
2. The Variable with either be multiplied or divided in unison.

For instance:

Looking at the $V=IR$ triangle, cover the V with your thumb thereby multiplying I & R .
or looking at the $P=IR$ triangle, covering up the I which will result in dividing P by V .

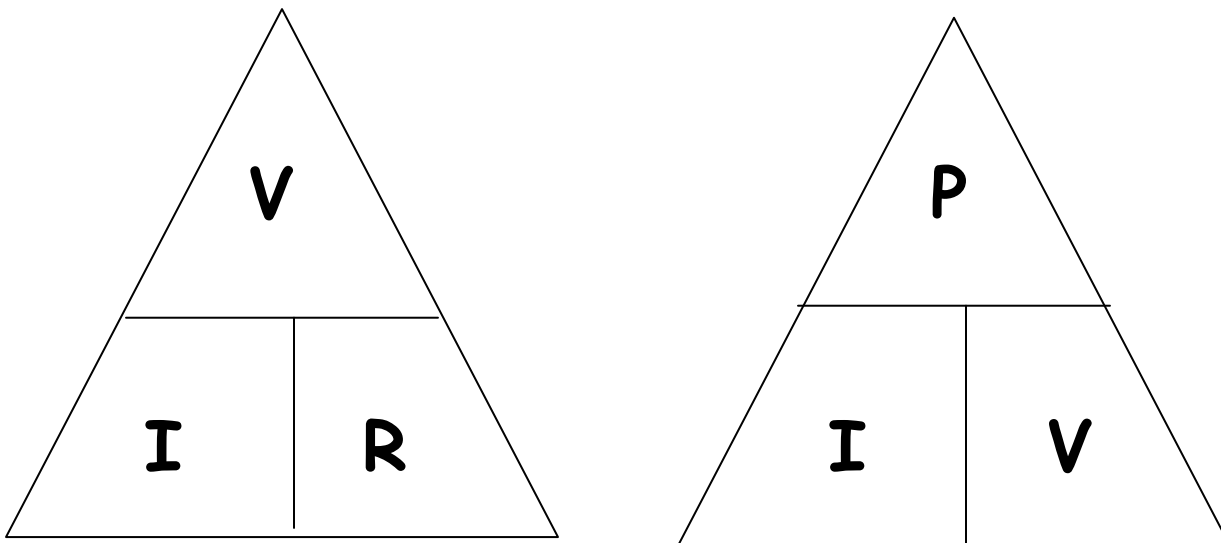

Voltage: The electrical potential developed between any two points. Usually, one of the points is referred to as the ground or negative end of a portion of a circuit. In an Alternating Current circuit, the voltage is constant, while in a Direct Current circuit; the voltage begins to decay or decrease the instant you close that circuit. Closing a circuit means all the ends are connected for electrical flow to start, while an open circuit has a "gap" and there is no electrical flow.

Current: The rate of flowing charge from one part of a circuit to another. There are two types of flow: alternating (wall outlet) or direct (batteries).

Resistance: Opposition to the flow of current: its role is similar to that of mechanical friction. A voltage drop follows a resistor in a circuit.

Power: The time rate of expanding energy or rate of doing work.

LED (Light Emitting Diode): Display devices are a common requirement in electrical systems. Examples include: clock display, VCR & DVD displays, modern automobile indicators, remote controllers, and even seen on the hoods of some cars these days. LEDs are considered solid-state electronic devices and are very reliable and durable. These devices are extremely small light sources and exist in a variety of colors, which is uncommon with conventional bulbs. An LED is made of two parts: an anode (arrow) and a cathode (bar). Current must flow from the anode to the cathode, which means current must flow in one direction for a diode to work; hence the directional arrow of the anode. A resistor is placed in *series* with LED to regulate the current flow. The brightness of the LED is proportional to the current flowing into it.

Series Circuit

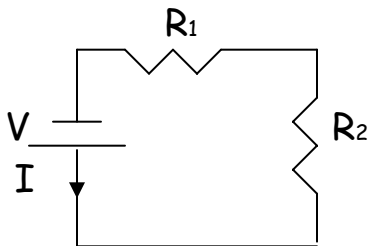

Parallel Circuit

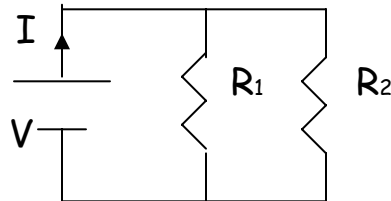

Discuss in class:

One major difference between parallel and series circuitry:

- In a series circuit, the circuit is open if just one resistor does not work. The bad resistor blocks current, since there is only one route for the current to flow.
- In a parallel circuit, the circuit is still closed even if one or more, but not all resistors are working. This means current will find its way through the circuit using another route as you can see from the diagram.

Discuss some example(s) of parallel & series circuitry

Parallel & Series Circuits (examples):

All electrical devices are based on parallel and series circuits.

Example of Parallel Circuitry:

- Home wiring
- Some Christmas lights: Those that do work even if one or more bulbs is missing.

Example of Series Circuitry:

- CD player and radio.
- Some Christmas lights: Those which do not work when at least one bulb does not work.

TRANSFORMERS



Photo of:
City Public Service of San Antonio

When cities and towns distribute electric power to our homes and schools, safety and efficiency are the two highest priorities of energy suppliers such as City Public Service. In fact, many people are not yet familiar with how electricity is transported from the power plant to their home. This process is not as complex as some may imagine. Electricians and engineers prefer to deal with low voltage at both the generating end (electric power plant) and the receiving end (home or office). Nobody wants an electric toaster or a hairdryer to operate at 10,000 Volts (10kV).

A transformer is a device, which can raise (for transmission) and lower (for use) the voltage in a circuit. It has no moving parts and operates by Faraday's Law of Induction. A common transformer consists of two coils:

- The primary winding of N_1 turns connected to an alternating current source (AC)
- The secondary winding of N_2 turns connected to a Load Resistor R_L

Let's look at how a CPS power plant transforms and transports power to be used at our homes.

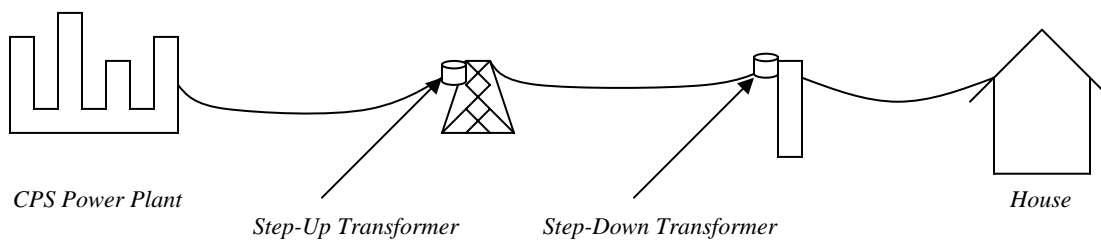

We must recognize that wire is a resistor and absorbs electrical potential, especially when CPS is transporting electricity to users many miles away. As the length of the wire increases, a higher "step-up" is needed for the voltage to reach the next transformer, which "steps-down" the voltage to 110V to 220V for a home outlet.

We must recognize that wire is a resistor and absorbs electrical potential, especially when CPS is transporting electricity to users many miles away. As the length of the wire increases, a higher "step-up" is needed for the voltage to reach the next transformer, which "steps-down" the voltage to 110V to 220V for a home outlet.

Figure 1 Step-Down Transformer (similar to AC adapter or transformer next to home)

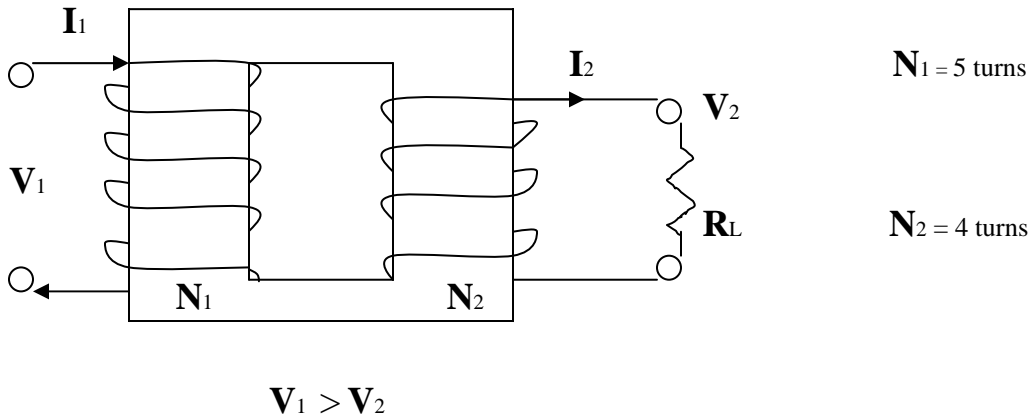
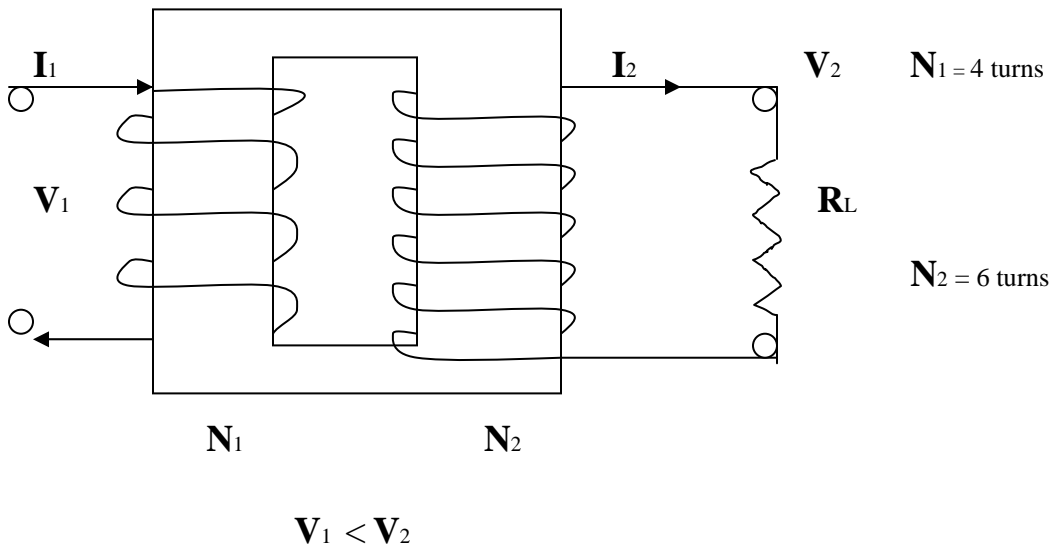

Figure 2: Step-Up Transformer



Transformers

Example: (to be covered by instructor in class to illustrate the concepts of electricity as it is transported from the Power Plant to a home)

Let's consider a 726,000 V (726kV) line of carrying 500 Amps to transmit electric energy from the Spruce Power Plant (Calaveras Lake) to UTSA-1604, 48 km (approx. 30 mi) apart. The resistance of the wire per kilometer is about 0.220Ω/km

Example)

How much Power is dissipated in this transportation process?

{You will need to recall Ohm's Law and Power eqns from PREP I: $P = I V$, $V = I R$ }

(1) What values do we need to solve this problem? Voltage, Current, Resistance, & Distance

(2) What do we know about this situation?

$$V = 726,000 \text{ V}$$

$$I = 500 \text{ A}$$

$$d = 48 \text{ km}$$

We still need the value for Resistance, so let's find it:

We must consider that electric power lines act as a resistor, and. For a the 48km stretch between Spruce and UTSA, the total resistance is:

(3) $(0.220\Omega/\text{km}) \times (48\text{km}) = 10.6 \Omega$

(4) Energy (power) is supplied at a rate of:

$$P_{av} = I V = (500\text{A}) \times (726,000\text{V}) = 363,000,000 \text{ Watts}$$

$$\xi \text{ is sometimes used instead of } V \quad (363 \text{ MW})$$

(5) With respect to this resistance, energy is dissipated at a rate of:

$$P_{av} = I \times (V=IR) = I^2 R = (500\text{A})^2 \times (10.6\Omega) = 2,650,000 \text{ Watts}$$

$$(2.65 \text{ MW})$$

We can loose over 2.65 million Watts of electricity, which is about 9.6% energy loss from the initial supply rate of 363 MW.

Transformers:

Example)

Consider a transformer connected to a utility pole outside of a home and the voltage at the outlet of the home is 160V. The windings within the transformer are: $N_1 = 375$ turns & $N_2 = 2$ turns.

What is the voltage entering the transformer ?

(1) What values are we given?

$$N_1 = 375$$

$$N_2 = 2$$

$$V_2 = 160V \text{ output}$$

{Since we're analyzing the Voltage at the transformer, let's consider the voltage exiting, which is also the voltage at the outlet, the output voltage}

(2) What are we solving?

Initial Voltage V_1

(3) Set-up equation:

$$(V_2 / V_1) = (N_2 / N_1)$$

After algebraic manipulation

$$V_1 = V_2 (N_1 / N_2)$$

To solve for V_1

(4) Substitute known values into equation & solve for V_1 :

$$V_1 = 160V (375 / 2)$$

$$\mathbf{V_1 = 30,000 Volts}$$

Electrical Cost Analysis

Let's consider a 100 Watt light bulb left on in a room for 1 full month (31 days).

CPS charges about \$0.08 per kWh (kilowatt x hour) for San Antonio, TX on average.

Example)

At this rate, how much will CPS charge for this single source of light for the month?

Note: Units for the light bulb must be converted from Watt to kilowatt, & for time, days to hours

(1) $100W = 0.1kW = 100 \times 10^{-3} kW$ (Scientific notation conversion)

$$(31 \text{ days}) (24 \text{ hours / day}) = 744 \text{ hours in 1 month}$$

(2) What do we know?

$$\text{Rate} = \$0.08 / kWh$$

$$\text{Time} = 31 \text{ days} = 744 \text{ hours} = 1 \text{ month}$$

$$\text{Power} = 100W = 0.1 kW$$

(3) What are we trying to solve? Cost

Cost = Rate x Time x Power

$$\text{Cost} = (\$0.08 / kWh) \times (744 \text{ hours}) \times (0.1 kW) = \underline{\underline{\$5.95 \text{ per month}}}$$

AC Adapter

AC adapters are commonly used to charge mobile phones and power many appliances such as CD players, electric can openers and pencil sharpeners. These adapters can be external and internal. An AC adapter is "mini" transformer usually incased in a plastic cover or placed directly inside the appliance or component. Voltage ranges from 110V to 220V at every outlet in the U.S. Since voltage is not constant and resistance is, current is also arbitrary depending on the resistance.

Let's say an AC adapter, which supplies power to a pair of computer speakers transforms 120V to 12V. We know 120V (on average) is drawn from an AC outlet, but the CD player only requires 12V to operate. This means that the AC adapter will have an input of 120V and an output of 12V

- **What type of transformer is used in this situation?**
- **If the adapter had an input of 120V and an output of 200V, what type of transformer is this?**

Example:

A wall voltage provides an input of 120V and the adapter (transformer) has an output of 12V as mentioned above.

What is the turn ratio within the transformer?

(1) What do we know about the situation (what values are we given) ?

We know the voltages **V1** & **V2**

(2) What are we solving for?

We are solving for the turn ratio (**N2 / N1**)

(3) Set up equation:

$$(V2 / V1) = (N2 / N1)$$

(5) **Solve for the ratio: (N2 / N1) by substituting known values into equation:**

$$(N2 / N1) = (12V / 120V) = (1 \text{ turn} / 10 \text{ turns})$$

Ans:

N1 = 10 turns (for input of 120V)

N2 = 1 turn (for output of 12V)

This is a Step-Down transformer

(1 / 10) is the smallest ratio or (12 / 120) in lowest terms.

II. Optics

Ref: <http://www.glenbrook.k12.il.us/gbssci/phys/Class/BBoard.html>

[This bending of the path of light is known as **refraction**. A one-word synonym for refraction is "bending." The transmitted wave experiences this refraction at the boundary. As seen in the diagram at the right, each individual wavefront is bent only along the boundary. Once the wavefront has passes across the boundary, it travels in a straight line. For this reason, refraction is called a boundary behavior. A ray is drawn perpendicular to the wavefronts; this ray represents the direction which the light wave is traveling. Observe that the ray is a straight line inside of each of the two media, but bends at the boundary. Again, refraction is a boundary behavior.]

[In this unit, we will rely heavily on the use of rays to represent the direction which a wave is moving. While we know that light is a wave (and not a stream of particles), we will still use a line segment with and an arrowhead (i.e., a ray) to depict the refraction of light. The ray is constructed in a direction perpendicular to the wavefronts of the light wave; this accurately depicts the light wave's direction. The idea that a light wave can be represented by a ray is known as the ray model of light.]

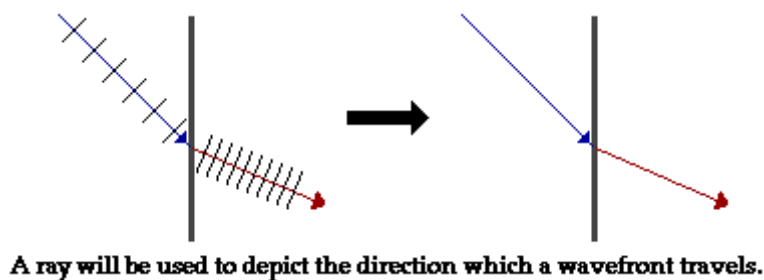

<http://www.glenbrook.k12.il.us/gbssci/phys/Class/BBoard.html>

This directing of our sight in a specific direction is sometimes referred to as the **line of sight**.

[As light travels through a given medium, it travels in a straight line. However, when light passes from one medium into a second medium, the light path bends; refraction takes place. The refraction occurs only at the boundary. Once the light has crossed the boundary between the two media, it continues to travel in a straight line; only now, the direction of that line is different than it was in the former medium. If when sighting at an object, light from that object changes media on the way to your eye, a visual distortion is likely to occur. This visual distortion was witnessed in The Broken Pencil activity performed in class. A pencil was submerged in water and viewed from the side. As you sighted at the portion of the pencil located above the water's surface, light travels directly from the pencil to your eye. Since this light does not change medium, it will not refract. As you sighted at the portion of the pencil which was submerged in the water, light traveled from water to air (or from water to glass to air). This light ray changed medium and subsequently underwent refraction. As a result, the image of the pencil appears to

be broken. Furthermore, the portion of the pencil which is submerged in water appears to be wider than the portion of the pencil which is not submerged.]

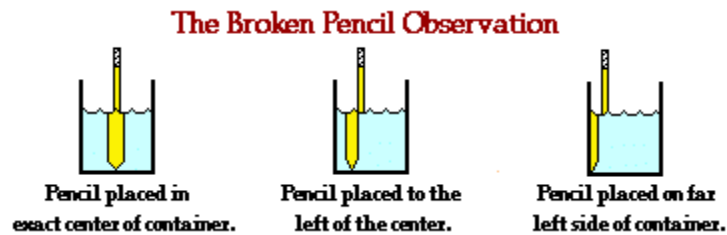

<http://www.glenbrook.k12.il.us/gbssci/phys/Class/BBoard.html>

[Quite obviously, these observations can be explained by the refraction of light. In this case, the only light which undergoes refraction is the light which travels from the submerged portion of the pencil, through the water, across the boundary, into the air, and ultimately to the eye. At the boundary, this ray refracts. The eye-brain interaction cannot account for the refraction of light. As was emphasized in Unit 13, the brain judges the image location to be the location where light rays appear to originate from. This image location is the location where either reflected or refracted rays intersect. The eye and brain assume that light travels in a straight line and then extends all incoming rays of light backwards until they intersect. Light rays from the submerged portion of the pencil will intersect in a different location than light rays from the portion of the pencil which extends above the surface of the water. For this reason, the submerged portion of the pencil appears to be in a different location than the portion of the pencil which extends above the water. The diagram at the right shows a God's-eye view of the light path from the submerged portion of the pencil to each of your two eyes. Only the left and right extremities (edges) of the pencil are considered. The blue lines depict the path of light to your right eye and the red lines depict the path of light to your left eye. Observe that the light path has bent at the boundary. Dashed lines represent the extensions of the lines of sight backwards into the water. Observe that the these extension lines intersect at a given point; the point represents the image of the left and the right edge of the pencil. Finally, observe that the image of the pencil is wider than the actual pencil. A ray model of light which considers the refraction of light at boundaries adequately explains the broken pencil observations.]

Refraction

[We have learned that refraction occurs as light passes across the boundary between two medium. Refraction is merely one of several possible boundary behaviors by which a light wave could behave when it encounters a new medium or an obstacle in its path. The transmission of light across a boundary between two medium is accompanied by a change in both the speed and wavelength of the wave. The light wave not only changes directions at the boundary, it also speeds up or slows down and transforms into a wave with a larger or a shorter wavelength. The only time that a wave can be transmitted across a boundary, change its speed, and still not refract is when the light wave approaches the boundary in a direction which is perpendicular to it. As long as the light wave changes speed and approaches the boundary at an angle, refraction is observed.]

[But why does light refract? What is the cause of such behavior? And why is there this one exception to the refraction of light? These questions were investigated in the Marching Soldiers activity performed in class. A group of students formed a straight line (shoulder to shoulder) and connected themselves to their nearest neighbor by meter sticks. A strip of masking tape divided the room into two "media." In one of the media (on one side of the tape), students walked at a normal pace. In the other media (or on the other side of the tape), students walked very slowly using baby steps. The group of students walked forward in a straight line towards the diagonal strip of masking tape; the students maintained a line as they approached the masking tape. When an individual student reached the tape, that student abruptly changed the pace of her/his walk. The group of students continued walking until all students in the line had entered into the second medium. The diagram below represents the line of students approaching the boundary between the two medium (the masking tape). On the diagram, an arrow is used to show the general direction of travel for the group of students in both medium. Observe that the direction of the students changes at the "boundary."]

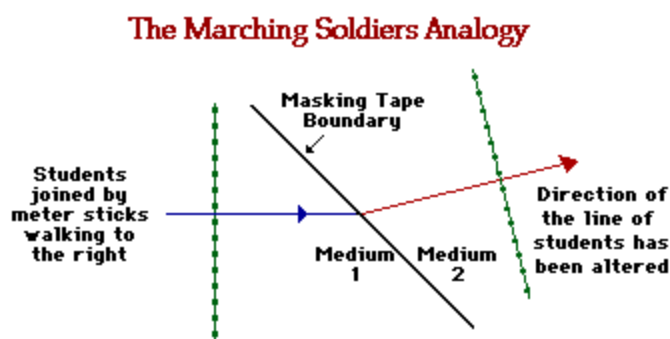

<http://www.glenbrook.k12.il.us/gbssci/phys/Class/BBoard.html>

[The fundamental feature of the students' motion which led to this change in direction was the change in speed. Upon reaching the masking tape, each individual student abruptly changed speed. Because the students approached the masking tape at an angle, each individual student reached the tape at a different time. The student who reaches the tape first, slowed down while the rest of the line of students marched ahead. This occurs for every student in the line of students; once a student reaches the boundary, that student slowed down while his/her nearest neighbor marched ahead at the original pace. The result was that the direction that the line of students was heading was altered at the boundary. The change in speed of the line of students caused a change in direction.]

But will this *refractive* behavior always occur? No! There are two conditions which are required in order to observe the change in direction of the path of the students:

- The students must change speed when crossing the boundary.
- The students must approach the boundary at an angle; refraction will not occur when they approach the boundary "head-on" (i.e., heading perpendicular to it).

[These are both reasonable enough conditions if you consider the previous paragraph. If the students do not change speed, then there is no *cause* factor. Recall that it was the change in speed of the students which caused the change in direction. The second condition is also reasonable. If the students approach the masking tape in a direction which is perpendicular to it, then each student will reach the tape at the exact same time. Recall that the line of student changed

their direction because they had reached the masking tape at different times. The first student reached the tape, slowed down, and observed the rest of the students marching ahead at the original speed. The change in direction of the line of students only occurs at the boundary when the students change speed and approach at an angle.]

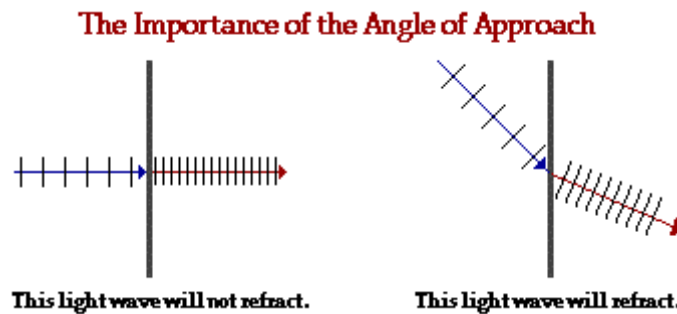

<http://www.glenbrook.k12.il.us/gbssci/phys/Class/BBoard.html>

The same two conditions which are necessary for bending the path of the line of students are also necessary for bending the direction of a light ray. Light refracts at a boundary because of a change in speed. There is a distinct cause-effect relationship; the change in speed is the cause and the change in direction (refraction) is the effect.

Optical Density and the Speed of Light

[Refraction is the bending of the path of a light wave as it passes from one material to another material. The refraction occurs at the boundary and is caused by a change in the speed of the light wave upon crossing the boundary. The tendency of a ray of light to bend one direction or another is dependent upon whether the light wave speeds up or slows down upon crossing the boundary. Because a major focus of our study will be upon the direction of bending, it will be important to understand the factors which effect the speed at which a light wave is transported through a medium.]

- The mechanism by which a light wave is transported through a medium occurs in a manner that is similar to the way that any other wave is transported - by particle interaction. Now, let's take a look at this method in more detail:

[An electromagnetic wave (i.e., a light wave) is produced by a vibrating electric charge. As the wave moves through the vacuum of empty space, it travels at a speed of c (3×10^8 m/s). This value is the speed of light in a vacuum. When the wave impinges upon a particle of matter, the energy is absorbed and sets electrons within the atoms into vibrational motion. If the frequency of the electromagnetic wave does not match the resonant frequency of vibration of the electron, then the energy is reemitted in the form of an electromagnetic wave. This new electromagnetic wave has the same frequency as the original wave and it too will travel at a speed of c through the empty space between atoms. The newly emitted light wave continues to move through the interatomic space until it impinges upon a neighboring particle. The energy is absorbed by this new particle and sets the electrons of its atoms into vibration motion. And once more, if there is no match between the frequency of the electromagnetic wave and the resonant frequency of the electron, the energy is reemitted in the form of a new electromagnetic wave. The cycle of absorption and reemission continues as the energy is transported from particle to particle through the bulk of a medium. Every photon (bundle of electromagnetic energy) travels between the interatomic void at a speed of c ; yet time delay involve in the process of being absorbed and

reemitted by the atoms of the matter lowers the net speed of transport from one end of the medium to the other. Subsequently, the net speed of an electromagnetic wave in any medium is somewhat less than its speed in a vacuum - c (3×10^8 m/s).]

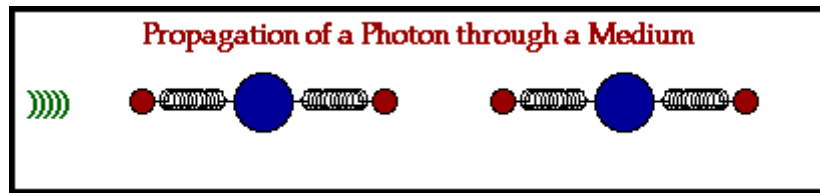

<http://www.glenbrook.k12.il.us/gbssci/phys/Class/BBoard.html>

[Like any wave, the speed of a light wave is dependent upon the properties of the medium. In the case of an electromagnetic wave, the speed of the wave depends upon the **optical density** of that material. The optical density of a medium is not the same as its physical density. The physical density of a material refers to the mass/volume ratio. The optical density of a material relates to the sluggish tendency of the atoms of a material to maintain the absorbed energy of an electromagnetic wave in the form of vibrating electrons before reemitting it as a new electromagnetic disturbance. The more optically dense which a material is, the slower that a wave will move through the material.]

[One indicator of the optical density of a material is the **index of refraction value** of the material. Index of refraction values (represented by the symbol n) are numerical index values which are expressed relative to the speed of light in a vacuum. The index of refraction value of a material is a number which indicates the number of times slower that a light wave would be in that material than it is in a vacuum. A vacuum is given an n value of 1.0000. The n values of other materials are found from the following equation:

$$n_{\text{material}} = \frac{3.00 \times 10^8 \text{ m/s}}{v_{\text{material}}}$$

[The table below lists index of refraction values for a variety of medium. The materials listed at the top of the table are those through which light travels fastest; these are the least optically dense materials. The materials listed at the bottom of the table are those through which light travels slowest; these are the most optically dense materials. So as the index of refraction value increases, the optical density increases, and the speed of light in that material decreases.]

<http://www.glenbrook.k12.il.us/gbssci/phys/Class/BBoard.html>

Material	Index of Refraction	
Vacuum	1.0000	<--lowest optical density
Air	1.0003	
Ice	1.31	
Water	1.333	
Ethyl Alcohol	1.36	
Plexiglas	1.51	

Crown Glass	1.52	
Light Flint Glass	1.58	
Dense Flint Glass	1.66	
Zircon	1.923	
Diamond	2.417	
Rutile	2.907	
Gallium phosphide	3.50	<--highest optical density

Refraction Angle

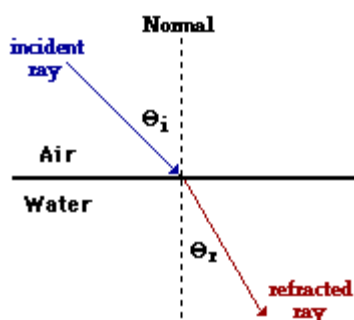

<http://www.glenbrook.k12.il.us/gbssci/phys/Class/BBoard.html>

[Refraction is the bending of the path of a light wave as it passes across the boundary separating two media. Refraction is caused by the change in speed experienced by a wave when it changes medium. Earlier, we learned that if a light wave passes from a medium in which it travels slow (relatively speaking) into a medium in which it travels fast, then the light wave will refract away from the normal. In such a case, the refracted ray will be farther from the normal line than the incident ray; this is the SFA rule of refraction. On the other hand, if a light wave passes from a medium in which it travels fast (relatively speaking) into a medium in which it travels slow, then the light wave will refract towards the normal. In such a case, the refracted ray will be closer to the normal line than the incident ray is; this is the FST rule of refraction. These two rules regarding the refraction of light only indicate the direction which a light ray bends; they do not indicate how much bending occurs. Lesson 1 focused on the topics of "What causes refraction?" and "Which direction does light refract?" The question is: "By how much does light refract when it crosses a boundary?" Perhaps there are numerous answers to such a question. (For example, "a lot," "a little," "like wow! quite a bit dude," etc.) The concern of this lesson is to express the amount of refraction of a light ray in terms of a measurable quantity that has a mathematical value. The diagram to the right shows a light ray undergoing refraction as it passes from air into water. As previously mentioned, the **incident ray** is a ray (drawn perpendicular to the wavefronts) shows the direction which light travels as it approaches the boundary. Similarly, the **refracted ray** is a ray (drawn perpendicular to the wavefronts) which shows the direction which light travels after it has crossed over the boundary. In the diagram, a normal line is drawn to the surface at the point of incidence; this line is always drawn perpendicular to the boundary. The angles which the incident ray makes with the normal line is referred to as the **angle of incidence**. Similarly, the angle which the refracted ray makes with the normal line is referred to as the **angle of refraction**. The angles of incidence and angles of refraction are denoted by the following symbols:

θ_i = angle of incidence

θ_r = angle of refraction

[The amount of bending which a light ray experiences can be expressed in terms of the angle of refraction (more accurately, by the difference between the angle of refraction and the angle of incidence). A ray of light may approach the boundary at an angle of incidence of 45-degrees and bend towards the normal. If the medium into which it enters causes a small amount of refraction, then the angle of refraction might be a value of about 42-degrees. On the other hand if the medium into which the light enters causes a large amount of refraction, the angle of refraction might be 22-degrees. (These values are merely arbitrarily chosen values to illustrate a point.) The diagram below depicts a ray of light approaching three different boundaries at an angle of incidence of 45-degrees. The refractive medium is different in each case, causing different amounts of refraction. The angles of refraction are shown on the diagram.]

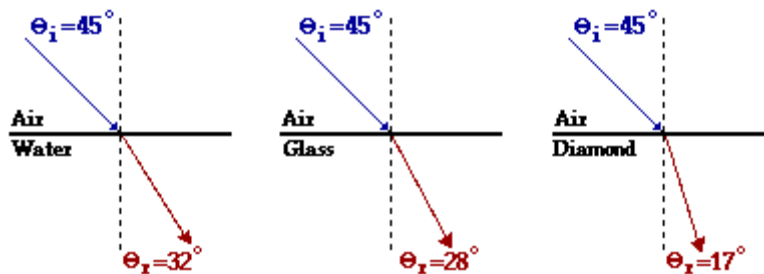

[Of the three boundaries in the diagram above, the light ray refracts the most at the air-diamond boundary. This is evident by the fact that the difference between the angle of incidence and the angle of refraction is greatest for the air-diamond boundary. But how can this be explained? The cause of refraction is a change in light speed; and wherever the light speed changes most, the refraction is greatest. We have already learned that the speed is related to the optical density of a material which is related to the index of refraction of a material. Of the four materials present in the above diagram, air is the least dense material (lowest index of refraction value) and diamond is the most dense material (largest index of refraction value). Thus, it would be reasonable that the most refraction occurs for the transmission of light across an air-diamond boundary.]

Snell's Law

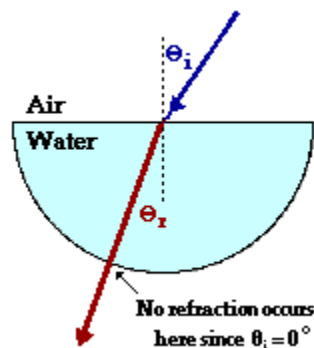

<http://www.glenbrook.k12.il.us/gbssci/phys/Class/BBoard.html>

[Refraction is the bending of the path of a light wave as it passes across the boundary separating two media. Refraction is caused by the change in speed experienced by a wave when it changes medium. The more that light refracts, the bigger the difference between these two angles.]

[To begin, consider a hemi-cylindrical dish filled with water. Suppose that a laser beam is directed towards the flat side of the dish at the exact center of the dish. The angle of incidence can be measured at the point of incidence. This ray will refract, bending towards the normal (since the light is passing from a medium in which it travels fast into one in which it travels slow - FST). Once the light ray enters the water, it travels in a straight line until it reaches the second boundary. At the second boundary, the light ray is approaching along the normal to the curved surface (this stems from the geometry of circles). The ray does not refract upon exiting since the angle of incidence is 0-degrees (recall the Secret of the Archer Fish). The ray of laser light therefore exits at the same angle as the refracted ray of light made at the first boundary. These two angles can be measured and recorded. The angle of incidence of the laser beam can be changed to 5-degrees and new measurements can be made and recorded. This process can be repeated until a complete data set of accurate values has been collected. The data below show a representative set of data for such an experiment.]

<http://www.glenbrook.k12.il.us/gbssci/phys/Class/BBoard.html>

Angle of Incidence (degrees)	Angle of Refraction (degrees)
0.00	0.00
5.00	3.76
10.0	7.50
15.0	11.2
20.0	14.9
25.0	18.5
30.0	22.1
35.0	25.5
40.0	28.9
45.0	32.1
50.0	35.2
55.0	38.0
60.0	40.6
65.0	43.0
70.0	45.0
75.0	46.6
80.0	47.8
85.0	48.5

[An inspection of the data above reveal that there is no clear linear relationship between the angle of incidence and the angle of refraction. For example, a doubling of the angle of incidence from 40 degrees to 80 degrees does not result in a doubling of the angle of refraction. Thus, a plot of these data would not yield a straight line. If however, the sine of the angle of incidence and the sine of the angle of refraction were plotted, the plot would be a straight line, indicating a linear relationship between the sines of the important angles. If two quantities form a straight line on a graph, then a mathematical relationship can be written in $y = m \cdot x + b$ form. A plot of the sine of the angle of incidence vs. the sine of the angle of refraction is shown below.]

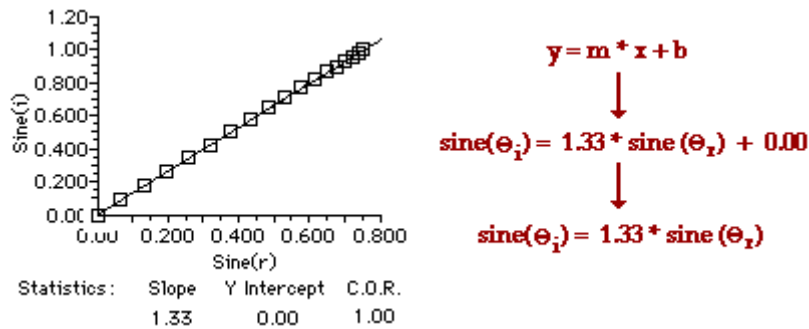

<http://www.glenbrook.k12.il.us/gbssci/phys/Class/BBoard.html>

The equation relating the angles of incidence ("theta i") and the angle of refraction ("theta r") for light passing from air into water is given as:

$$\text{sine}(\theta_i) = 1.33 * \text{sine}(\theta_r)$$

[Observe that the constant of proportionality in this equation is 1.33 - the index of refraction value of water. Perhaps it's just a coincidence. But if the semi-cylindrical dish full of water was replaced by a semi-cylindrical disk of Plexiglas, the constant of proportionality would be 1.51 - the index of refraction value of Plexiglas. This is not just a coincidence. The same pattern would result for light traveling from air into any material.] Experimentally, it is found that for a ray of light traveling from air into some given material, the following equation can be written as:

$$\text{sine}(\theta_i) = n_{\text{material}} * \text{sine}(\theta_r)$$

where n_{material} = **index of refraction of the material**

This study of the refraction of light as it crosses from one material into a second material yields a general relationship between the sines of the angle of incidence and the angle of refraction. This general relationship is expressed by the following equation:

$$n_i * \text{sine}(\theta_i) = n_r * \text{sine}(\theta_r)$$

where θ_i ("theta i") = angle of incidence
 θ_r ("theta r") = angle of refraction
 n_i = index of refraction of the incident medium
 n_r = index of refraction of the refractive medium

This relationship between the angles of incidence and refraction and the indices of refraction of the two medium is known as **Snell's Law**. Snell's law will apply to the refraction of light in any situation, regardless of what the two media are.

The equation is known as the Snell's Law equation and is expressed as follows.

$$n_i \cdot \sin(\theta_i) = n_r \cdot \sin(\theta_r)$$

where θ_i ("theta i") = angle of incidence

θ_r ("theta r") = angle of refraction

n_i = index of refraction of the incident medium

n_r = index of refraction of the refractive medium

<http://www.glenbrook.k12.il.us/gbssci/phys/Class/BBoard.html>

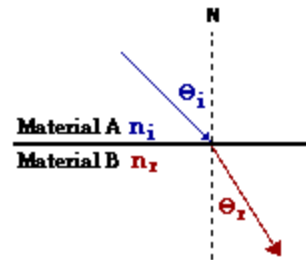

Example:

A ray of light in air is approaching the boundary with water at an angle of 52 degrees. Determine the angle of refraction of the light ray. Refer to the table of indices of refraction if necessary.

The solution to this problem begins like any problem: a diagram is constructed to assist in the visualization of the physical situation, the known values are listed, and the unknown value (desired quantity) is identified. This is shown below:

Diagram:



Given:

$$n_i = 1.00 \text{ (from table)}$$

$$n_r = 1.333 \text{ (from table)}$$

$$\theta_i = 52 \text{ degrees}$$

<http://www.glenbrook.k12.il.us/gbssci/phys/Class/BBoard.html>

Example:

A ray of light in air is approaching the a layer of crown glass at an angle of 42.0 degrees. Determine the angle of refraction of the light ray upon entering the crown glass and upon leaving the crown glass. Refer to the table of indices of refraction if necessary.

Diagram:

Given:

Find:

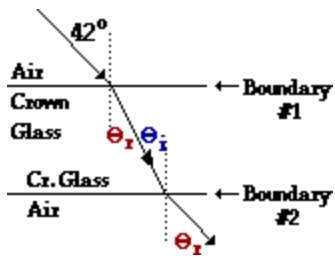

Note that the angle of refraction at boundary #1 is the same as the angle of incidence at boundary #2.

Boundary #1

$$n_i = 1.00 \text{ (from table)}$$

$$n_r = 1.52 \text{ (from table)}$$

$$\theta_i = 42.0 \text{ degrees}$$

Boundary #2

$$n_i = 1.52 \text{ (from table)}$$

$$n_r = 1.00 \text{ (from table)}$$

θ_{rat}

boundary #1

and

θ_{rat}

boundary #2

Boundary #1:

$$n_i \cdot \sin(\theta_i) = n_r \cdot \sin(\theta_r)$$

$$1.00 \cdot \sin(42.0 \text{ degrees}) = 1.52 \cdot \sin(\theta_r)$$

$$0.669 = 1.52 \cdot \sin(\theta_r)$$

$$0.4402 = \sin(\theta_r)$$

$$\sin^{-1}(0.4402) = \sin^{-1}(\sin(\theta_r))$$

$$26.1 \text{ degrees} = \theta_r$$

Boundary #2:

$$n_i \cdot \sin(\theta_i) = n_r \cdot \sin(\theta_r)$$

$$1.52 \cdot \sin(26.1 \text{ degrees}) = 1.00 \cdot \sin(\theta_r)$$

$$1.52 \cdot (0.4402) = 1.00 \cdot \sin(\theta_r)$$

$$0.6691 = \sin(\theta_r)$$

$$\sin^{-1}(0.6691) = \sin^{-1}(\sin(\theta_r))$$

$$42.0 \text{ degrees} = \theta_r$$

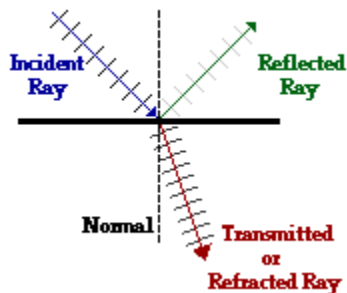

<http://www.glenbrook.k12.il.us/gbssci/phys/Class/BBoard.html>

[A light wave, like any wave, is an energy-transport phenomenon. A light wave transports energy from one location to another. When a light wave strikes a boundary between two distinct media, a portion of the energy will be transmitted into the new medium and a portion of the energy will be reflected off the boundary and stay within the original medium. The actual percentage of energy which is transmitted and

reflected is dependent upon a number of variables; these will be discussed as we proceed through Lesson 3. For now, our concern is to review and internalize the basic concepts and terminology associated with boundary behavior. Reflection of a light wave involves the bouncing of a light wave off the boundary, while refraction of a light wave involves the bending of the path of a light wave upon crossing a boundary and entering a new medium. Both reflection and refraction involve a change in direction of a wave, but only refraction involves a change in medium.]

[The diagram at the right shows several wavefronts approaching a boundary between two media. These wavefronts are referred to as the incident waves and the ray which points in the direction which they are traveling is referred to as the **incident ray**. The incident ray is drawn in blue on the diagram at the right. Notice on the diagram that the incident ray *leads into* two other rays at the point of incidence with the boundary. The reflected waves are the waves which bounce off the boundary and head back upwards and the **reflected ray** is the ray which points in the direction which the reflected waves are traveling. The reflected ray is drawn in green on the diagram at the right. The refracted waves are the waves which are transmitted across the boundary and continues moving downwards, only at a different angle than before; the refracted ray is the ray which points in the direction which the refracted waves are traveling. The refracted ray is drawn in red on the diagram at the right. At the **point of incidence** (the point where the incident ray strikes the boundary), a **normal line** is drawn. The normal line is always drawn perpendicular to the surface at the point of incidence. The normal line creates a variety of angles with the light rays; these angles are important and are given special names. The angle between the incident ray and the normal is the **angle of incidence**. The angle between the reflected ray and the normal is the **angle of reflection**. And the angle between the refracted ray and the normal is the **angle of refraction**.]

The fundamental law which governs the reflection of light is called the **law of reflection**. Whether the light be reflecting off a rough surface or a smooth surface, a curved surface or a planar surface, the light ray follows the law of reflection.

The law of reflection states:

- When a light ray reflects off a surface, the angle of incidence is equal to the angle of reflection.

The fundamental law which governs the reflection of light is **Snell's Law**.

Snell's Law states:

- When a light ray is transmitted into a new medium, the relationship between the angle of incidence and the angle of refraction is given by the following equation $n_i \cdot \sin(\theta_i) = n_r \cdot \sin(\theta_r)$

where the n_i and n_r values represent the indices of refraction of the incident and the refractive medium respectively.

The Anatomy of a Lens:

If a piece of glass or other transparent material takes on the appropriate shape, it will be capable of taking parallel rays of incident light and either converging them to a point or appear to diverge them from a point. Such a piece of glass is referred to as a lens.

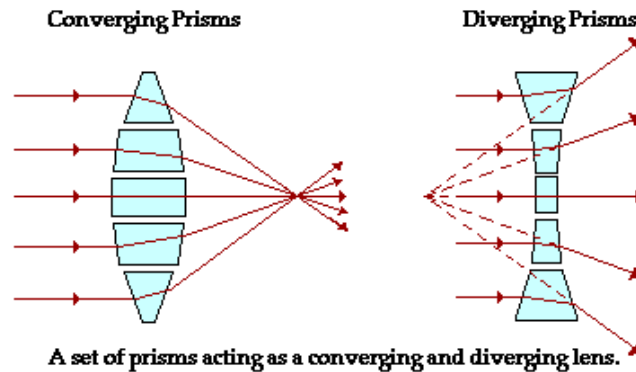

<http://www.glenbrook.k12.il.us/gbssci/phys/Class/BBoard.html>

[A **lens** is merely a carefully ground or molded piece of transparent material which refracts light rays in such a way as to form an image. Lenses can be thought of as a series of tiny refracting lenses, each of which refracts light to produce their own image. When these prisms act together, they produce a bright enough image focused at a point. There are a variety of types of lenses. Lenses differ from one another in terms of their shape and the materials from which they are made. Our focus will be upon lenses which are symmetrical across their horizontal axis - known as the **principal axis**. In this unit, we will categorize lenses as converging lenses and diverging lenses. A **converging lens** is a lens which converges rays of light which are traveling parallel to its principal axis. Converging lenses can be identified by their shape; they are thicker across their middle and thinner at their upper and lower edges. A **diverging lens** is a lens which diverges rays of light which are traveling parallel to its principal axis. Diverging lenses can also be identified by their shape; they are thinner across their middle and thicker at their upper and lower edges.]

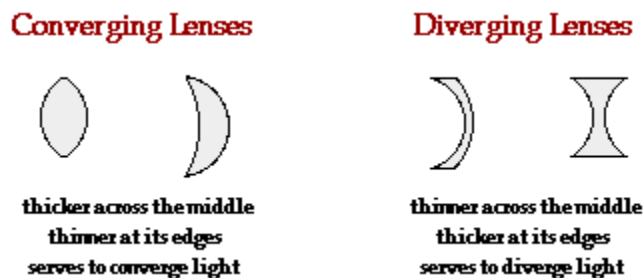

<http://www.glenbrook.k12.il.us/gbssci/phys/Class/BBoard.html>

[A **double convex lens** is symmetrical across both its horizontal and vertical axis. Each of the lens' two faces can be thought of as originally being part of a sphere. The fact that a double convex lens is thicker across its middle is an indicator that it will converge rays of light which travel parallel to its principal axis. A double convex lens is a converging lens. A **double concave lens** is also symmetrical across both its horizontal and vertical axis. The two faces of a double concave lens can be thought of as originally being part of a sphere. The fact that a double concave lens is thinner across

its middle is an indicator that it will diverge rays of light which travel parallel to its principal axis. A double concave lens is a diverging lens. These two types of lenses - a double convex and a double concave lens will be the only types of lenses which will be discussed in class.]



<http://www.glenbrook.k12.il.us/gbssci/phys/Class/BBoard.html>

As we begin to discuss the refraction of light rays and the formation of images by these two types of lenses, we will need to use a variety of terms. Many of these terms should be familiar to you because they have already been introduced. If you are uncertain of the meaning of the terms, should spend some time reviewing them so that their meaning is firmly internalized in your mind. They will be essential as we proceed through the following material. These terms describe the various parts of a lens and include such words as the following:

1. Principal Axis
2. Focal Point
3. Vertical Plane
4. Focal Length

[If a symmetrical lens is thought of as being a slice of a sphere, then there would be a line passing through the center of the sphere and attaching to the mirror in the exact center of the lens. This imaginary line is known as the **principal axis**. A lens also has an imaginary **vertical axis** which bisects the symmetrical lens in two. As mentioned above, light rays incident towards either face of the lens and traveling parallel to the principal axis will either converge or diverge. If the light rays converge (as in a converging lens), then they will converge to a point. This point is known as the **focal point** of the converging lens. If the light rays diverge (as in a diverging lens), then the diverging rays can be traced backwards until they intersect at a point. This point is known as the **focal point** of a diverging lens. The focal point is denoted by the letter **F** on the diagrams below. Note that each lens has two focal points - one on each side of the lens. Unlike mirrors, lenses can allow light to pass through either face, depending on where the incident rays are coming from. Subsequently, every lens has two possible focal points. The distance from the mirror to the focal point is known as the **focal length** (abbreviated by "f"). Technically, a lens does not have a center of curvature (at least not one which has any importance to our discussion).]

However a lens does have an imaginary point we refer to as the **2F point**. This is the point on the principal axis that is twice as far from the vertical axis as the focal point is:

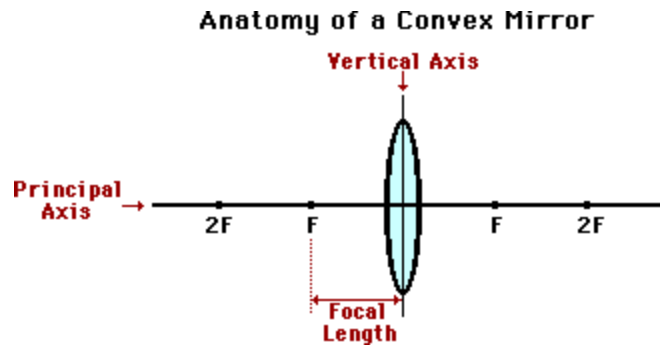

<http://www.glenbrook.k12.il.us/gbssci/phys/Class/BBoard.html>

As we discuss the characteristics of images produced by converging and diverging lenses, these vocabulary terms will become increasingly important. Remember that this page is here and refer to it as often as needed.

[First lets consider a double convex lens. Suppose that several rays of light approach the lens; and suppose that these rays of light are traveling parallel to the principal axis. Upon reaching the front face of the lens, each ray of light will refract towards the normal to the surface. At this boundary, the light ray is passing from air into a more dense medium (usually plastic or glass). Since the light ray is passing from a medium in which it travels fast (less optically dense) into a medium in which it travels slow (more optically dense), it will bend towards the normal line; this is the FST principle of refraction. This is shown for two incident rays on the diagram below. Once the light ray refracts across the boundary and enters the lens, it travels in a straight line until it reaches the back face of the lens. At this boundary, each ray of light will refract away from the normal to the surface. Since the light ray is passing from a medium in which it travels slow (more optically dense) to a medium in which it travels fast (less optically dense), it will bend away from the normal line; this is the SFA principle of refraction.]

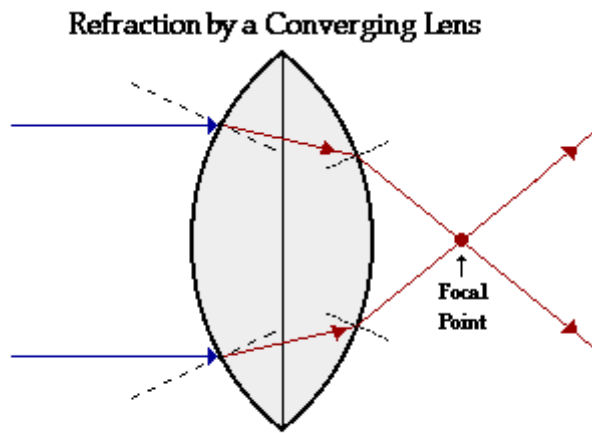

Incident rays which travel parallel to the principal axis will refract through the lens and converge to a point.

<http://www.glenbrook.k12.il.us/gbssci/phys/Class/BBoard.html>

The previous diagram shows the behavior of two incident rays approaching parallel to the principal axis. Note that the two rays converge at a point; this point is known as the focal point of the lens. The first generalization, which can be made for the refraction of light by a double convex lens is as follows:

Refraction Rule for a Converging Lens

Any incident ray traveling parallel to the principal axis of a converging lens will refract through the lens and travel through the focal point on the opposite side of the lens.

[Now suppose that the rays of light are traveling through the focal point on the way to the lens. These rays of light will refract when they enter the lens and refract when they leave the lens. As the light rays enter into the more dense lens material, they refract towards the normal; and as they exit into the less dense air, they refract away from the normal. These specific rays will exit the lens traveling parallel to the principal axis.]

Refraction by a Converging Lens

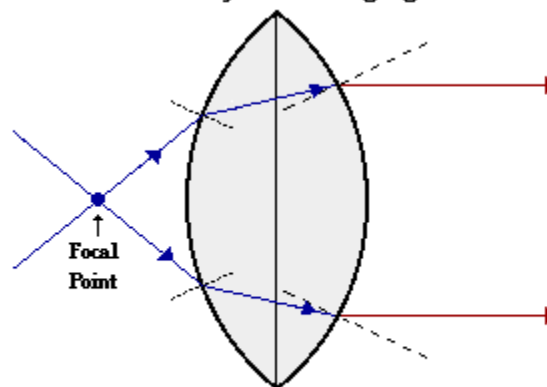

Incident rays which travel through the focal point will refract through the lens and travel parallel to the principal axis.

Thin Lens Approximation

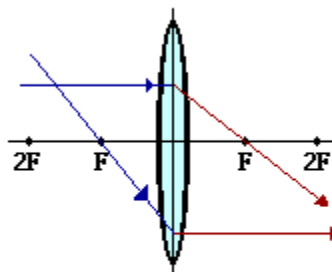

In the construction of incident and refracted rays, the light can merely be bent at the vertical axis. This creates the same result as refracting the light rays twice.

The previous diagram shows the behavior of two incident rays traveling through the focal point on the way to the lens. Note that the two rays refract parallel to the principal axis. A second generalization for the refraction of light by a double convex lens can be added to the first generalization.

Refraction Rules for a Converging Lens

- Any incident ray traveling parallel to the principal axis of a converging lens will refract through the lens and travel through the focal point on the opposite side of the lens.
- Any incident ray traveling through the focal point on the way to the lens will refract through the lens and travel parallel to the principal axis.

[These two "rules" will greatly simplify the task of determining the image location for objects placed in front of converging lenses. Now, internalize the meaning of the rules and be prepared to use them. As the rules are applied in the construction of ray diagrams, do not forget the fact that Snell's Law of refraction of light holds for each of these rays. It just so happens that geometrically, when Snell's Law is applied for rays which strike the lens in the manner described above, they will refract in close approximation with these two rules. The tendency of incident light rays to follow these rules is increased for lenses which are thin. For such thin lenses, the path of the light through the lens itself contributes to very little change in the direction of the light rays. We will use this so-called thin-lens approximation in this unit. Furthermore, to simplify the construction of ray diagrams, we will avoid refracting each light ray twice - upon entering and emerging from the lens. Instead, we will continue the incident ray to the vertical axis of the lens and refract the light at that point. For thin lenses, this simplification will produce the same result as if we were refracting the light twice.]

Now, let's investigate the refraction of light by double concave lens. Suppose that several rays of light approach the lens; and suppose that these rays of light are traveling parallel to the principal axis. Upon reaching the front face of the lens, each ray of light will refract towards the normal to the surface. At this boundary, the light ray is passing from air into a more dense medium (usually plastic or glass). Since the light ray is passing from a medium in which it travels fast (less optically dense) into a medium in which it travels slow (more optically dense), it will bend towards the normal line; this is the FST principle of refraction.

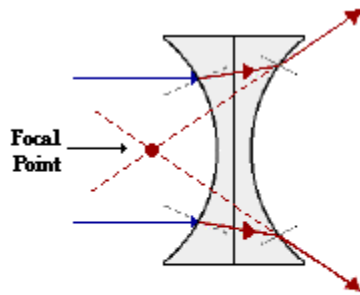

A diverging lens is said to have a negative focal length since rays which enter the lens traveling parallel to the principal axis diverge.

<http://www.glenbrook.k12.il.us/gbssci/phys/Class/BBoard.html>

This is shown for two incident rays on the diagram ahead. Once the light ray refracts across the boundary and enters the lens, it travels in a straight line until it reaches the back face of the lens. At this boundary, each ray of light will refract away from the normal to the surface. Since the light ray is passing from a medium in which it travels slow (more optically dense) to a medium in which it travels fast (less optically dense), it will bend away from the normal line; this is the SFA principle of refraction. These principles of refraction are identical to what was observed for the double convex lens above.

Refraction by a Diverging Lens

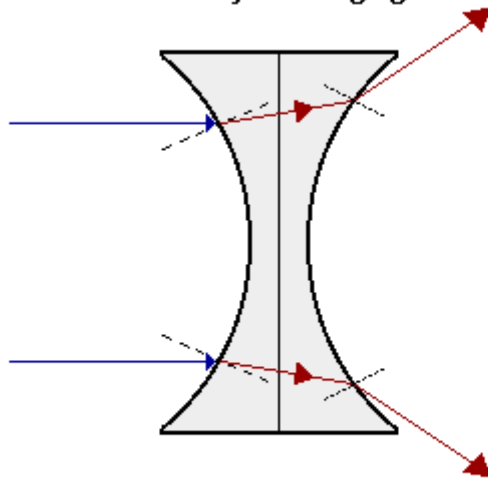

Incident rays traveling parallel to the principal axis will refract through the lens and diverge, never intersecting.

<http://www.glenbrook.k12.il.us/gbssci/phys/Class/BBoard.html>

The above diagram shows the behavior of two incident rays approaching parallel to the principal axis of the double concave lens. Just like the the double convex lens above, light bends towards the normal when entering and away from the normal when exiting the lens. Yet, because of the different shape of the double concave lens, these incident rays are not converged to a point upon refraction through the lens. Rather, these incident rays diverge upon refracting through the lens. For this reason, a double concave lens can never produce a real image. Double concave lenses produce images which are virtual. If the refracted rays are extended backwards behind the lens, an important observation is made. The extension of the refracted rays will intersect at a point. This point is known as the focal point. Notice that a diverging lens such as this double concave lens does not really focus the light rays which are parallel to the principal axis; rather, it diverges these light rays. For this reason, a diverging lens is said to have a negative focal length.

The first generalization can now be made for the refraction of light by a double concave lens:

Refraction Rule for a Diverging Lens

Any incident ray traveling parallel to the principal axis of a diverging lens will refract through the lens and travel *in line with* the focal point (i.e., in a direction such that its extension will pass through the focal point).

Now, suppose that the rays of light are traveling towards the focal point on the way to the lens. Because of the negative focal length for double concave lenses, the light rays will head towards the focal point on the opposite side of the lens. These rays will actually reach the lens before they reach the focal point. These rays of light will refract when they enter the lens and refract when they leave the lens. As the light rays enter into the more dense lens material, they refract towards the normal; and as they exit into the less dense air, they refract away from the normal. These specific rays will exit the lens traveling parallel to the principal axis, as seen below:

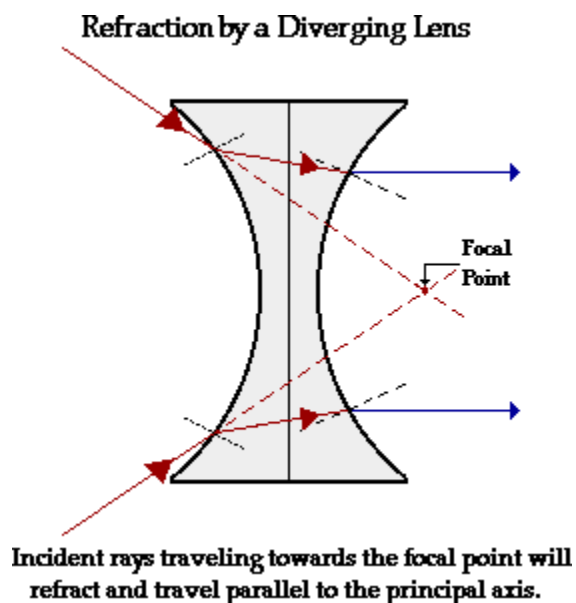

The above diagram shows the behavior of two incident rays traveling through the focal point on the way to the lens. Note that the two rays refract parallel to the principal axis. A second generalization for the refraction of light by a double concave lens can be added to the first generalization.

Refraction Rules for a Diverging Lens

- Any incident ray traveling parallel to the principal axis of a diverging lens will refract through the lens and travel *in line with* the focal point (i.e., in a direction such that its extension will pass through the focal point).
- Any incident ray traveling towards the focal point on the way to the lens will refract through the lens and travel parallel to the principal axis.

The previous discussion focuses on the manner in which converging and diverging lenses refract incident rays which are traveling parallel to the principal axis or are traveling through (or towards) the focal point. But these are not the only two possible incident rays. There are a multitude of incident rays which strike the lens and refract in a variety of ways. Yet, there are three specific rays which behave in a very predictable manner. The third ray, which we will examine, is the ray which passes through the precise center of the lens - through the point where the principal axis and the vertical axis intersect. This ray will refract as it enters and refract as it exits the lens, but the net effect of this dual refraction is that the path of the light ray is not changed. For a **thin lens**, the refracted ray is traveling in the same direction as the incident ray and is approximately in line with it. The behavior of this third incident ray is depicted in the diagram below.

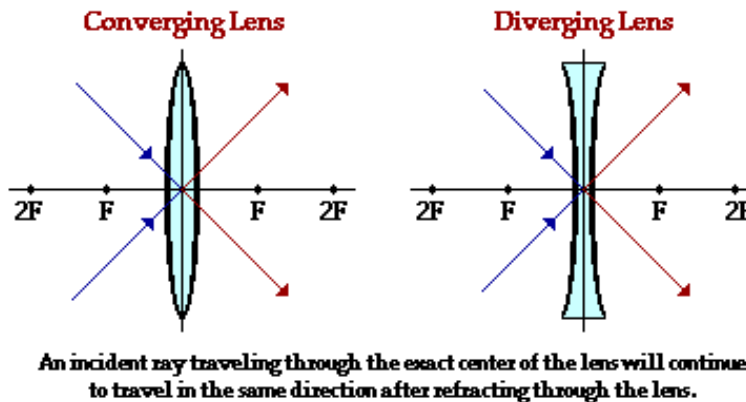

<http://www.glenbrook.k12.il.us/gbssci/phys/Class/BBoard.html>

Now, we have three incident rays whose refractive behavior is simply predicted. These three rays lead to our three "rules" of refraction for converging and diverging lenses. These three rules are summarized on the next page:

Refraction Rules for a Converging Lens

- Any incident ray traveling parallel to the principal axis of a converging lens will refract through the lens and travel through the focal point on the opposite side of the lens.
- Any incident ray traveling through the focal point on the way to the lens will refract through the lens and travel parallel to the principal axis.
- An incident ray which passes through the center of the lens will in effect continue in the same direction that it had when it entered the lens.

Refraction Rules for a Diverging Lens

- Any incident ray traveling parallel to the principal axis of a diverging lens will refract through the lens and travel *in line with* the focal point (i.e., in a direction such that its extension will pass through the focal point).
- Any incident ray traveling towards the focal point on the way to the lens will refract through the lens and travel parallel to the principal axis.
- An incident ray which passes through the center of the lens will in effect continue in the same direction that it had when it entered the lens.

<http://www.glenbrook.k12.il.us/gbssci/phys/Class/BBoard.html>

[These three "rules" of refraction for converging and diverging lenses will be applied through the remainder of this lesson. The rules merely describe the behavior of three specific incident rays. While there are a multitude of light rays being captured and refracted by a lens, only two rays are needed in order to determine the image location. So as we proceed with this lesson, use pick your favorite two rules (usually, the ones which are easiest to remember) and apply them to the construction of ray diagrams and the determination of the image location and characteristics.]

References

1.

“Introduction to Physics” & “Past to Present”

“Algebra & Geometry Review”

“Measurements & Data Analysis”

<http://www.glenbrook.k12.il.us/gbssci/phys/Class/BBoard.html>

http://en.wikipedia.org/wiki/Main_Page

<http://www.grc.nasa.gov/WWW/K-12/aerores.htm>

http://www.collegeboard.com/prod_downloads/ap/students/physics/info_equation_tables_2002.pdf

Introduction to Engineering Curriculum PREP I

Problem Solving - Geometry Curriculum PREP I

<http://www.glenbrook.k12.il.us/gbssc>

<http://www.aerospaceweb.org/question/aerodynamics/q0094b.shtml>

<http://www.aerospaceweb.org/design/aerospoke/figures/fig01.gif>

http://www.the-rocketman.com/archive_photos/funny_nozzle.jpg

2

“Momentum & Inertia”

“Scalars & Vectors”

“Forces”

“Rotational Motion”

<http://www.glenbrook.k12.il.us/gbssci/phys/Class/BBoard.html>

http://en.wikipedia.org/wiki/Main_Page

<http://www.grc.nasa.gov/WWW/K-12/aerores.htm>

http://www.collegeboard.com/prod_downloads/ap/students/physics/info_equation_tables_2002.pdf

Introduction to Engineering Curriculum PREP I

Problem Solving - Geometry Curriculum PREP I

Photo of:

Texas Department of Transportation

<http://www.glenbrook.k12.il.us/gbssc>

<http://www.aerospaceweb.org/question/aerodynamics/q0094b.shtml>

<http://www.aerospaceweb.org/design/aerospoke/figures/fig01.gif>

http://www.the-rocketman.com/archive_photos/funny_nozzle.jpg

3.

“Statics”

“Motion”

“Newton’s Laws of Motion”

<http://www.glenbrook.k12.il.us/gbssci/phys/Class/BBoard.html>

http://en.wikipedia.org/wiki/Main_Page

<http://www.grc.nasa.gov/WWW/K-12/aerores.htm>

http://www.collegeboard.com/prod_downloads/ap/students/physics/info_equation_tables_2002.pdf

Introduction to Engineering Curriculum PREP I

Problem Solving - Geometry Curriculum PREP I

Photo of:

Texas Department of Transportation

<http://www.glenbrook.k12.il.us/gbssc>

<http://www.aerospaceweb.org/question/aerodynamics/q0094b.shtml>

<http://www.aerospaceweb.org/design/aerospoke/figures/fig01.gif>

http://www.the-rocketman.com/archive_photos/funny_nozzle.jpg

4.

“Kinematics & Dynamics”

<http://www.glenbrook.k12.il.us/gbssci/phys/Class/BBoard.html>

http://en.wikipedia.org/wiki/Main_Page

<http://www.grc.nasa.gov/WWW/K-12/aerores.htm>

http://www.collegeboard.com/prod_downloads/ap/students/physics/info_equation_tables_2002.pdf

Introduction to Engineering Curriculum PREP I

Problem Solving - Geometry Curriculum PREP I

Photo of:

Texas Department of Transportation

<http://www.glenbrook.k12.il.us/gbssc>

<http://www.aerospaceweb.org/question/aerodynamics/q0094b.shtml>

<http://www.aerospaceweb.org/design/aerospoke/figures/fig01.gif>

http://www.the-rocketman.com/archive_photos/funny_nozzle.jpg

5.

“Work & Energy”

“Potential Energy”

“Kinetic Energy”

<http://www.glenbrook.k12.il.us/gbssci/phys/Class/BBoard.html>

http://en.wikipedia.org/wiki/Main_Page

<http://www.grc.nasa.gov/WWW/K-12/aerores.htm>

http://www.collegeboard.com/prod_downloads/ap/students/physics/info_equation_tables_2002.pdf

Introduction to Engineering Curriculum PREP I

Problem Solving - Geometry Curriculum PREP I

Photo of:

Texas Department of Transportation

<http://www.glenbrook.k12.il.us/gbssc>

<http://www.aerospaceweb.org/question/aerodynamics/q0094b.shtml>

<http://www.aerospaceweb.org/design/aerospoke/figures/fig01.gif>

http://www.the-rocketman.com/archive_photos/funny_nozzle.jpg

6.

“Fluid Mechanics”

<http://www.glenbrook.k12.il.us/gbssci/phys/Class/BBoard.html>

http://en.wikipedia.org/wiki/Main_Page

<http://www.grc.nasa.gov/WWW/K-12/aerores.htm>

http://www.collegeboard.com/prod_downloads/ap/students/physics/info_equation_tables_2002.pdf

Introduction to Engineering Curriculum PREP I

Problem Solving - Geometry Curriculum PREP I

Photo of:

Texas Department of Transportation

<http://www.glenbrook.k12.il.us/gbssc>

<http://www.aerospaceweb.org/question/aerodynamics/q0094b.shtml>

<http://www.aerospaceweb.org/design/aerospoke/figures/fig01.gif>

http://www.the-rocketman.com/archive_photos/funny_nozzle.jpg

7.

“Electricity”

“Transformers (City Public Service of San Antonio)”

“Optics”

<http://www.glenbrook.k12.il.us/gbssci/phys/Class/BBoard.html>

http://en.wikipedia.org/wiki/Main_Page

<http://www.grc.nasa.gov/WWW/K-12/aerores.htm>

http://www.collegeboard.com/prod_downloads/ap/students/physics/info_equation_tables_2002.pdf

Introduction to Engineering Curriculum PREP I

Problem Solving - Geometry Curriculum PREP I

Photo of:

City Public Service of San Antonio